

IEEE Std 111-2000
(Revision of
IEEE Std 111-1984)

IEEE Standard for Wide-Band (Greater Than 1 Decade) Transformers

IEEE Power Electronics Society

Sponsored by the
Electronics Transformer Technical Committee



Published by
The Institute of Electrical and Electronics Engineers, Inc.
3 Park Avenue, New York, NY 10016-5997, USA

28 September 2001

Print: SH94808
PDF: SS94808

IEEE Standard for Wide-Band (Greater Than 1 Decade) Transformers

Sponsor

**Electronics Transformer Technical Committee
of the
IEEE Power Electronics Society**

Reaffirmed 26 September 2007

Approved 8 March 2000

IEEE-SA Standards Board

Abstract: Electronics wide-band transformers transmitting power within a wide band of frequencies covering typically at least one decade in the frequency spectrum are covered in this standard.

Keywords: Balance test, balun, communication transformer, data transformer, harmonic distortion, impedance, insertion loss, matching transformers, return loss, transformer, video transformer, wideband

The Institute of Electrical and Electronics Engineers, Inc.
3 Park Avenue, New York, NY 10016-5997, USA

Copyright © 2001 by the Institute of Electrical and Electronics Engineers, Inc.
All rights reserved. Published 28 September 2001. Printed in the United States of America.

Print: ISBN 0-7381-1928-8 SH94808
PDF: ISBN 0-7381-1926-6 SS94808

No part of this publication may be reproduced in any form, in an electronic retrieval system or otherwise, without the prior written permission of the publisher.

IEEE Standards documents are developed within the IEEE Societies and the Standards Coordinating Committees of the IEEE Standards Association (IEEE-SA) Standards Board. Members of the committees serve voluntarily and without compensation. They are not necessarily members of the Institute. The standards developed within IEEE represent a consensus of the broad expertise on the subject within the Institute as well as those activities outside of IEEE that have expressed an interest in participating in the development of the standard.

Use of an IEEE Standard is wholly voluntary. The existence of an IEEE Standard does not imply that there are no other ways to produce, test, measure, purchase, market, or provide other goods and services related to the scope of the IEEE Standard. Furthermore, the viewpoint expressed at the time a standard is approved and issued is subject to change brought about through developments in the state of the art and comments received from users of the standard. Every IEEE Standard is subjected to review at least every five years for revision or reaffirmation. When a document is more than five years old and has not been reaffirmed, it is reasonable to conclude that its contents, although still of some value, do not wholly reflect the present state of the art. Users are cautioned to check to determine that they have the latest edition of any IEEE Standard.

Comments for revision of IEEE Standards are welcome from any interested party, regardless of membership affiliation with IEEE. Suggestions for changes in documents should be in the form of a proposed change of text, together with appropriate supporting comments.

Interpretations: Occasionally questions may arise regarding the meaning of portions of standards as they relate to specific applications. When the need for interpretations is brought to the attention of IEEE, the Institute will initiate action to prepare appropriate responses. Since IEEE Standards represent a consensus of all concerned interests, it is important to ensure that any interpretation has also received the concurrence of a balance of interests. For this reason, IEEE and the members of its societies and Standards Coordinating Committees are not able to provide an instant response to interpretation requests except in those cases where the matter has previously received formal consideration.

Comments on standards and requests for interpretations should be addressed to:

Secretary, IEEE-SA Standards Board
445 Hoes Lane
P.O. Box 1331
Piscataway, NJ 08855-1331
USA

Note: Attention is called to the possibility that implementation of this standard may require use of subject matter covered by patent rights. By publication of this standard, no position is taken with respect to the existence or validity of any patent rights in connection therewith. The IEEE shall not be responsible for identifying patents for which a license may be required by an IEEE standard or for conducting inquiries into the legal validity or scope of those patents that are brought to its attention.

The IEEE and its designees are the sole entities that may authorize the use of IEEE-owned certification marks and/or trademarks to indicate compliance with the materials set forth herein.

Authorization to photocopy portions of any individual standard for internal or personal use is granted by the Institute of Electrical and Electronics Engineers, Inc., provided that the appropriate fee is paid to Copyright Clearance Center. To arrange for payment of licensing fee, please contact Copyright Clearance Center, Customer Service, 222 Rosewood Drive, Danvers, MA 01923 USA; (978) 750-8400. Permission to photocopy portions of any individual standard for educational classroom use can also be obtained through the Copyright Clearance Center.

Introduction

(This introduction is not a part of IEEE Std 111-2000, IEEE Standard for Wide-Band (Greater Than 1 Decade) Transformers.)

This standard is intended to provide a common ground for understanding between systems engineers and transformer design engineers. Little published data on transformers is directly useful to engineers designing systems involving feedback loops. Phase and frequency response data are needed on transformers (and other components) used in these systems. It is the hope that this standard will eventually influence transformer manufacturers to include such information in their published data on wide-band frequency transformers.

This standard is a combination of two original standards: IEEE Std 111-1971 and IEEE Std 264-1977. Both of these standards were first issued as trial-use documents in 1962 and 1965, respectively. These trial use documents were prepared under the chairmanship of A.D. Hasley and J.P. Whistler, respectively.

At the time this standard was approved, the frequency range subcommittee of the Electronics Transformers Technical Committee of the IEEE Power Electronics Society had the following members:

J. DeCramer, *Chair*

J. S. Andresen
R. Beers
E. D. Belanger*
R. P. Carey
C. J. Elliott
H. Fickenscher

B. D. Goethe
P. K. Goethe
R. R. Grant
N. R. Grossner*
H. E. Lee
D. N. Ratliff
R. L. Sell

J. Silgailis
J. Tardy
B. D. Thackwray
M. Wilkowski
R. Wozniak
H. Yarpezeskan

*Deceased

When the Electronics Transformer Technical Committee balloted and approved this standard, the membership was as follows:

J. DeCramer, *Chair*

J. S. Andresen
R. Beers
C. J. Elliott
B. D. Goethe

P. K. Goethe
R. R. Grant
R. Hasegawa

A. Lotfi
G. Skutt
B. D. Thackwray
M. Wilkowski

When the IEEE-SA Standards Board approved this standard on 8 March 2000, it had the following membership:

Donald N. Heirman, *Chair*

James T. Carlo, *Vice Chair*

Judith Gorman, *Secretary*

Satish K. Aggarwal
Mark D. Bowman
Gary R. Engmann
Harold E. Epstein
H. Landis Floyd
Jay Forster*
Howard M. Frazier
Ruben D. Garzon

James H. Gurney
Richard J. Holleman
Lowell G. Johnson
Robert J. Kennelly
Joseph L. Koepfinger*
Peter H. Lips
L. Bruce McClung
Daleep C. Mohla

James W. Moore
Robert F. Munzner
Ronald C. Petersen
Gerald H. Peterson
John B. Posey
Gary S. Robinson
Akio Tojo
Donald W. Zipse

*Member Emeritus

Also included is the following nonvoting IEEE-SA Standards Board liaison:

Alan Cookson, *NIST Representative*
Donald R. Volzka, *TAB Representative*

Andrew D. Ickowicz
IEEE Standards Project Editor

Contents

1.	Scope	1
1.1	General	1
1.2	Typical types of transformers to which this standard applies	1
2.	References	3
3.	Definitions	3
4.	Symbols	4
5.	Performance tests	6
5.1	Electrical tests (not recorded)	6
5.2	Electrical tests (recorded)	8
6.	Marking	18
6.1	Nameplate markings	18
6.2	Terminal markings	18
7.	Service conditions	19
8.	Computations	19
9.	Test methods	19
9.1	Temperature rise tests	19
9.2	Balance tests	20
9.3	Computations	20
9.4	Measurement of open-circuit and short-circuit inductance and resistance	28
9.5	Terminated impedance measurement	30
Annex A	(informative) Definitions and discussion	34
Annex B	(informative) Recommended practice for making electrical tests	36
Annex C	(informative) Service conditions	37
Annex D	(informative) Methods of computing time delay from phase shift measurements	38

IEEE Standard for Wide-Band (Greater Than 1 Decade) Transformers

1. Scope

1.1 General

This standard pertains to electronics wide-band transformers transmitting power within a wide band of frequencies covering typically at least one decade in the frequency spectrum. It is not intended to apply to transformers optimized to operate within a narrow band of frequencies. Transformers used in, or in conjunction with, wire line communication facilities serving power stations are excluded due to the special protection requirements involved. Provision is made for including data for use in the design of feedback amplifiers and control networks, or other circuits in which the knowledge of the transformer amplitude and phase-frequency response is needed by the system designer. These transformers are required to transform voltage within specified tolerances of amplitude and phase when operating between specified impedances. Guides to application and test procedures are included. The annexes within this standard contain certain precautions and recommended practices.

This standard also pertains to hybrid transformers, primarily used in the telecommunications industry. The hybrid transformer is a wide-band transformer used in a manner which makes it part of a capacitance, resistance, and/or inductance network, and it must have characteristics which permit it to match the network for proper overall performance.

1.2 Typical types of transformers to which this standard applies

1.2.1 Audio frequency transformers

Audio frequency transformers may cover a limited frequency range such as that used in voice communications, or may cover a part or all of the frequencies from 5 Hz to 100 000 Hz when used in high fidelity or similar amplifiers. Voltages or signals correspond directly to speech or music amplitude and phase variations within this range of frequencies. Performance characteristics one or more octaves beyond the specified range may be of interest and specified. Feedback and other windings or taps may be incorporated in the design. The mode or class of amplifier operation (i.e., Class A, B, AB, etc.) must be recognized and taken into consideration.

1.2.2 Transducer service transformers

Transducer service transformers are stepdown ratio transformers having one or more secondary windings with or without center taps. The load impedance may be permitted to vary with frequency or with other parameters, but the transformer performance is generally based on a specific load impedance.

1.2.3 Random noise transformers

Random noise transformers are used in vibration machine applications. They are subject to random signals of varying amplitude and duration. Response may be expressed in terms of the frequency spectrum but the amplitude variation allowable over the relevant frequency range is much greater than for audio-frequency transformers because of the Gaussian distribution of random noise. Random noise transformers are often included in feedback loops. When included in such a loop, their amplitude and phase response is of interest and all of the problems listed in 9.3 must be solved in addition to producing a transformer capable of handling the amplitude of random noise.

1.2.4 Modulation transformers

Modulation transformers are used in amplitude-modulated transmitters and may employ a modulation inductor to bypass the final amplifier supply current.

The transformer is used in a manner which makes it part of a capacitance, resistance, and inductance network, and it must have characteristics which permit it to match the network for proper overall performance. Phase angle, frequency response, and impedances are important measurements and are required to be made in the actual or substitute network with the major elements in place to establish performance. Modulation transformers are usually designed for specific applications and large units are not considered suitable for general purpose use.

1.2.5 Driver transformers

Driver transformers are used to supply power to the control elements of Class AB₂ and Class B₂ amplifier tubes and transistors.

1.2.6 Line-matching transformers

Line-matching transformers are used where power is received at one impedance level and delivered at another.

1.2.7 Load-matching autotransformers

Load-matching autotransformers are used where power is received at one impedance level and provides output taps at various impedances, and vice versa.

1.2.8 Control-system transformers

Control-system transformers are used in open- or closed-loop (feedback) control systems. The transformers used in the closed-loop system are subject to signals of a definite carrier frequency, modulated in accordance with error signals imposed by the control system requirements. The response of these transformers to control signals may be expressed either in terms of frequency and phase or in Laplace terms. In this standard, the phase and amplitude frequency response terms are used.

1.2.9 Ultrasonic frequency transformers

Ultrasonic frequency transformers are used in various communications and industrial applications in which the lowest frequency is higher than 10 kHz.

1.2.10 Carrier frequency transformers

Carrier frequency transformers transmit signals of specified frequency which are modulated or varied in amplitude, phase, or frequency.

1.2.11 Video frequency transformers

Video frequency transformers are characterized by an exceptional wide-band transmission characteristic over part or all of the range from 10 Hz to 10 Mhz for composite video, or 50 Mhz to 750 Mhz for commercial television applications.

Operated from solid-state power source devices. The use of Class AB₂ or Class B₂ current operation and their effect in the secondary winding must be recognized.

1.2.12 Single-core hybrid transformers

For single-core hybrid transformers, the hybrid function is provided by a single transformer in conjunction with external circuit elements.

1.2.13 Two-core hybrid transformers

For two-core hybrid transformers, the hybrid function requires two identical or essentially similar transformers in conjunction with external circuits.

NOTE: When inductors (reactors) are used in wide-band circuits, the required degree of linearity and self-resonance must be specified.

2. References

IEEE Std 389-1996, IEEE Recommended Practice for Testing Electronics Transformers and Inductors.

IEEE Std C57.98-1993, IEEE Guide for Transformer Impulse Tests.

3. Definitions

Electrical terms used in this standard shall be in accordance with those given in The Authoritative Dictionary of IEEE Standards Terms [B5].

3.1 conjugate branches (ports): Any two branches (ports) of a network such that a driving force impressed in either branch (port) produces little or no response in the other.

NOTE—In Figure 25, Z₀ and Z₃ are conjugate branches (ports) and Z₁ and Z₂ are likewise.

3.2 hybrid balance: The degrees of impedance balance between impedance Z₁ and Z₂ connected to two conjugate ports of a hybrid transformer (see Figure 25). Hybrid balance is measured as a return loss using one of the remaining two ports of the hybrid transformer as the sending end and the other as the receiving end. With reference return loss set to zero for Z₁= 0 or Z₂= 0, the measure of hybrid balance is given by:

$$20\log_{10} ((Z_2+Z_1)/(Z_2-Z_1)).$$

3.3 hybrid transformer: A transformer or transformer network with four distinct pairs of terminals designed to provide a means of achieving a balanced bridge condition so that transmission can take place between certain pairs of terminals while isolation is maintained between others.

3.4 trans-hybrid loss: The power delivered from one port of a hybrid transformer to its conjugate port is measured under two conditions:

Condition 1: When one of the other two ports is open-circuited.

Condition 2: When all ports are terminated in their proper impedances.

The ratio of the two powers, usually expressed in db, is defined as trans-hybrid loss.

4. Symbols

Symbol	Term denoted
a	transformer ratio
A, B, C, D	bridge corner designations
C_A, C_D	capacitance connected to bridge corners A and D, respectively
C_{AB}	capacitance connected between bridge corners A and B
C_P	distributed capacitance of primary winding
C_S	distributed capacitance of secondary winding
C_{sh}	effective parallel capacitance
e	variable ac potential source
E_O	output potential
E_I	input potential
f	frequency
f_1	low-frequency 1 dB point
f_2	high-frequency 1 dB point
f_0	$\sqrt{f_1 \cdot f_2}$ (mid-band frequency)
G_{AB}	conductance connected between bridge corners A and B
G_{sh}	conductance, $1/R_{sh}$
k	coefficient of coupling
L_L, L_{1L}, L_{2L}	leakage inductances
L_{11}	self-inductance; primary
L_{22}	self-inductance; secondary
L_{12}	mutual inductance; inductance common to primary and secondary
L_{sh}	shunt or parallel inductance
L_{ser}	series inductance
N_1, N_p	primary turns

Symbol	Term denoted
N_2, N_s	secondary turns
Q	quality factor
ρ	reflection coefficient
s	seconds
R_c	core loss resistance
R_p	primary winding resistance
R_s	secondary winding resistance
R_1, R_2, R_3, R_4	terminating resistance
R_A, R_B	resistance connected to bridge corners A and B, respectively
R_{AD}, R_{AB}, R_{BC}	resistance connected between bridge corners A and D, A and B, B and C, respectively
R_l, R_{1l}, R_{2l}	leakage resistances
R_L	load resistance
R_G	source resistance
R_{sh}	shunt or parallel resistance
R_{ser}	series resistance
t	temperature of winding, hot
t_1	reference temperature
t_o	temperature of winding, ambient
X_{ser}	series reactance
X_{sh}	shunt or parallel reactance ($2pL_{sh}$)
Y_{1O}	open-circuit admittance; primary side
Y_{2O}	open-circuit admittance; secondary side
Y_{1S}	short-circuit admittance; primary side
Y_{2S}	short-circuit admittance; secondary side
Z_L	load impedance
Z_G	source impedance
Z_O	standard source impedance
Z_{1O}	open circuit impedance, primary side
Z_{2O}	open-circuit impedance; secondary side
Z_{1S}	short-circuit impedance; primary side
Z_{2S}	short-circuit impedance; secondary side

5. Performance tests

The electrical tests listed here shall be performed according to IEEE Std 389-1996¹, unless otherwise stated.

5.1 Electrical tests (not recorded)

The following electrical tests should be made on all transformers, where practicable. The transformer terminals nominally grounded in service should be grounded during these tests, or connected as otherwise required or noted in the test description. The results of these need not be recorded.

5.1.1 Ratio of transformation (turns ratio)

5.1.2 Polarity

5.1.3 Electric strength tests

- 1) Transformer windings operating above 25 peak working volts (PWV) should have a test voltage equal to 1000 V plus 1.5 times the PWV applied between each winding and each other winding, and the core and the case (if the case is meant to be isolated from the core).
- 2) For the transformer windings with PWV 25 V and below, the test applied should be 500 V rms at 60 Hz or an equivalent test.
- 3) Test voltages should be increased gradually (at the rate of 2 kV per second maximum) from zero to the specified value, maintained for a period of 1 min, unless otherwise specified, and decreased to zero at the same rate.
- 4) The connection for windings not under test should be specified so that unwarranted stresses will not occur during the electrical strength tests. Windings with relatively low working voltages to ground should be grounded during the test of other windings to prevent the lower voltage insulation from being damaged through capacitive coupling.

The transformer or inductor windings, internally or externally grounded, or operated at direct voltages to ground and having one terminal grounded through a capacitor network, should be tested by induced voltage methods or a combination of the direct voltage strength test on the terminals to which direct voltage is directly applied together with the induced voltage, as applicable, instead of the standard electric strength test.

5.1.4 Induced voltage

An induced-voltage test is made at twice the maximum rated voltage, using a frequency of twice (or higher) the minimum rated frequency as agreed. In addition to this test, twice the rated direct voltage should be applied simultaneously for 1 min, or 7200 cycles, to the terminals normally connected to the direct voltage. This test should be performed as follows: the direct voltage (twice normal) should be first applied; then, by means of exciting a suitable winding, the alternating voltage should be increased from zero to twice normal over a 5 s interval², held for 60 s, and then decreased to zero over a 5 s interval. The input current should be monitored during the whole period. The normal voltage excitation current or loss should not have changed as a result of the test. During the test, all windings should be connected in the normal voltage relationship to each other and to ground.

For transformers not normally associated with direct-current stresses, an induced voltage of twice the operating alternating voltage at a frequency at least equal to three times the frequency of the low frequency 1 dB point should be applied to any convenient winding for a period of at least 10 s.

¹Information on references can be found in Clause 2.

²Minimum time, longer as required by 5.1.3, item (3).

5.1.5 Repeated electric strength testing

Since the application of test voltages may impair the strength of the transformer insulation, any test made per 5.1.3 and 5.1.4 should, if repeated, be made at not more than 80% of the specified test voltage and for the same interval, or for less time, if specified.

5.1.6 Corona tests

When specified the transformer shall be free from corona³ at the test level and at altitude conditions specified. (Normally corona tests are specified at test levels above 1000 V rms.)

- 1) Windings having an induced peak voltage equal to or less than 25% of the PWV for either end terminal (relatively low-voltage windings operating at a high potential above ground) shall be tested for corona with 130% of maximum operating voltage applied between windings and core. Terminals of windings tested should be shorted together. (Both operating and test voltages are assumed to be expressed in the same terms, either rms or peak.)
- 2) Windings having graded insulation should be tested under induced voltage conditions only and at 130% of maximum operating voltages. Winding potentials should be related to each other and to ground as in normal usage.
- 3) Windings having an induced peak voltage of more than 25% of the PWV for either end terminal, and not employing graded insulation should be tested for corona using either induced voltages or voltages to ground, as mutually agreed by maker and user.
- 4) For windings operating at other than zero direct voltage to ground, the corona test should be made with direct voltage plus alternating voltage. The applied voltages for this corona test should be 130% of the maximum operating instantaneous voltage.
- 5) In all cases above, the measure of the operating and test voltages should be the same; that is, either rms or peak.

5.1.7 Impulse tests

These tests may be specified for plate coupling transformers operating in excess of 800 V direct voltage and for transformers in other applications, where transient voltages may occur that are in excess of twice the PWV and where the PWV is greater than 1500 V. When so specified, these transformers should be capable of passing the impulse test hereunder.

Plate coupling transformer windings should be subjected to full wave and chopped wave impulse tests using a crest voltage equal to 10 times the maximum rated direct voltage. These tests should be made in accordance with 1.2.5 of IEEE Std C57.98-1993.

5.1.8 Shield test

When electrostatic shields are included in the specification, a test should be made to determine their effectiveness. This may be made as a direct capacitance measurement or other means if desired or specified, or both. When direct capacitance is measured, each winding should be short-circuited. See 16.1.3 of IEEE Std 389-1996.

5.1.9 Exciting-current and no-load loss

These characteristics should be measured when specified. The power source used for this test shall present a low enough impedance at harmonic frequencies so that the voltage applied to the transformer terminals is sinusoidal at fundamental frequency to within the required limits of accuracy.

³See Annex B for recommended measuring means.

5.1.10 Temperature-rise tests

These tests, when specified, should be made on a representative model of each new design before the transformer (component) is released to the customer, taking into account the specified or implied duty cycle. This test should be made in accordance with 9.1 of this standard.

5.2 Electrical tests (recorded)

The following standard electrical tests should be made when specified by the user. The transformer terminals normally grounded in service should be grounded, where practicable, during these tests. Response data may be recorded in the form of curves or charts and provided with the transformers.

5.2.1 Short-circuit impedance measurements

Short-circuit impedance measurements may be specified if variations in this parameter are important or if information is required for calculations. (See Figure 1, Figure 2, and Figure 3, and 9.3 and 9.4 of this standard.)

5.2.2 Amplitude-frequency response measurements (see Figure 4—Figure 7)

Amplitude-frequency response measurements may be plotted in any of the following ways: frequency response, transformer loss, and voltage amplification or attenuation. In this standard, amplitude-frequency response will be used (see Figure 4 and Figure 8). Specific measurements should normally be specified when the transformer is operating between matched resistive terminations; however, if variation in response is important or if the terminations actually encountered in operation are complex or nonlinear impedances, then the user may specify that the measurement be made with actual or simulated terminations. All terminals should be related to ground and to each other as in the actual intended circuit.

When the transformer is measured between matched resistive terminations, the requirements may be presented as a minimum typical curve to which the transformer will conform (see Figure 4 and Figure 8). When variations in the transformer response are important, as when used in a feedback loop, the amplitude-frequency response may be specified with an indicated tolerance (see Figure 7 and Figure 9).

Care should be taken in selecting applied voltage, since low-frequency response can be in error if there is insufficient magnetizing inductance (insufficient flux density). When the amplitude or phase response, or both, of a transformer varies substantially with the amplitude of the applied voltage, due to changes in magnetizing inductance and core loss with changes in flux density, the range of input voltages to the transformer should be specified. This may be represented by curves of the output voltage versus the input voltage, or by multiple curves of the amplitude response versus frequency for multiple values of applied signal level (see Figure 7).

It should be noted that the actual amplitude-frequency response of a transformer, which is included in a feedback loop or where the source or load, or both, impedances are not constant over the specified frequency range, may not correspond to that measured with fixed terminations.

5.2.3 Phase response measurements (see Figure 4 and Figure 5)

When terminated, as in 5.2.2, the requirements for phase response may be presented as a maximum typical curve of phase shift versus frequency to which the transformer should conform or to which measurements should be made at the same frequencies, as specified in 5.2.2, and with tolerances shown (see Figure 7, Figure 8, and Figure 9).

5.2.4 Time delay considerations

When terminated as in 5.2.2, the requirements for time delay may be presented as the maximum typical curve of delay in seconds versus frequency to which the transformer should conform (see Figure 10). The maximum tolerance shall be consistent with the maximum phase response tolerances of 5.2.3 (see Figure 7, Figure 8, and Figure 9). The time delay may be computed as

$$\text{Time delay} = \frac{(\text{change in phase})}{(\text{change in frequency})} \quad (1)$$

$$\text{Time delay} = \frac{(\text{degrees} \cdot 0.01745)}{(2 \cdot \pi \cdot \text{frequency})}$$

(Also see the definition for the term *envelope delay*, The Authoritative Dictionary of IEEE Standards Terms [B5]).

5.2.5 Harmonic distortion

Harmonic distortion measurements must be specified when the intended use of the transformer requires the absence or limitation of distortion of the output due to the nonlinear characteristics of the ferromagnetic core. Harmonic distortion is normally defined as the percent ratio of the harmonic power to the power of the fundamental signal present at the output of the transformer, with the input consisting of the fundamental frequency only. The transformer should be terminated as described in 5.2.2.

The harmonic response is determined as

$$\% \text{distortion} = 100 \cdot \frac{\sqrt{\sum_{i=2}^{I=\infty} e_i^2}}{e_1} \quad (2)$$

where

e_1 = rms value of the fundamental

e_i = rms value of the i th harmonic

For practical measurements, i is limited to be less than 10. It is often convenient to measure the value of the output with the fundamental frequency eliminated (filtered), and using the rms value of the combined harmonics to the rms value of the output as the ratio for distortion. This method will give less than 5% error in the distortion value when the total distortion is less than 30%.

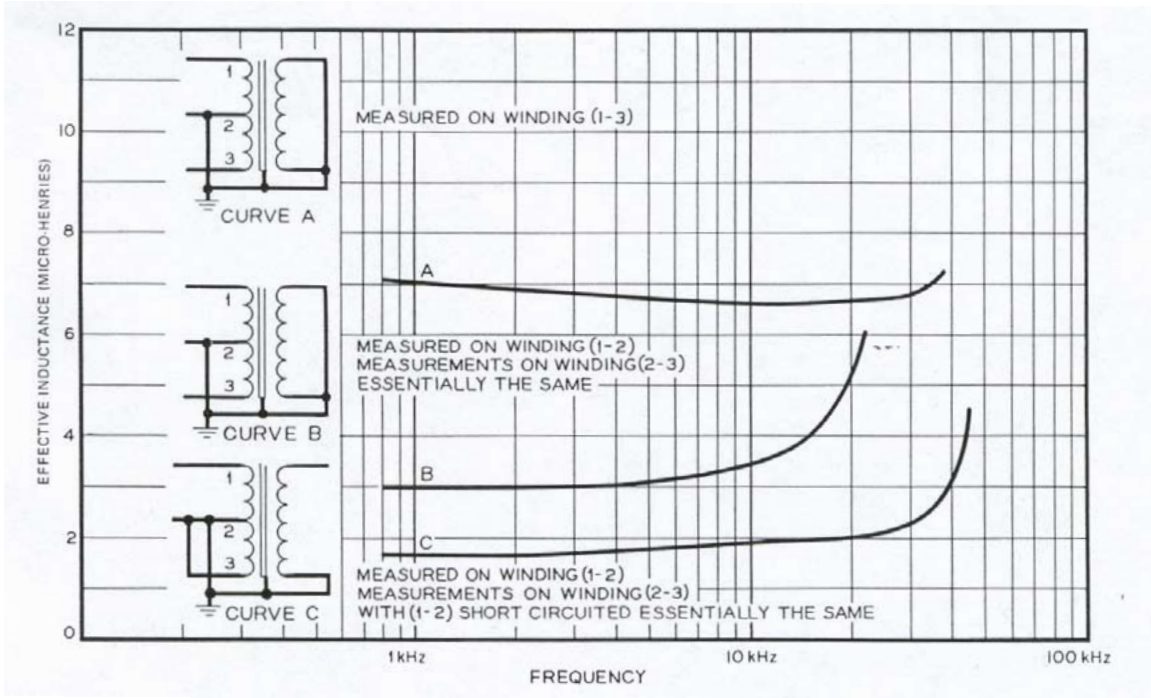

Figure 1—Example of an effective series inductance and resistance with various windings short-circuited

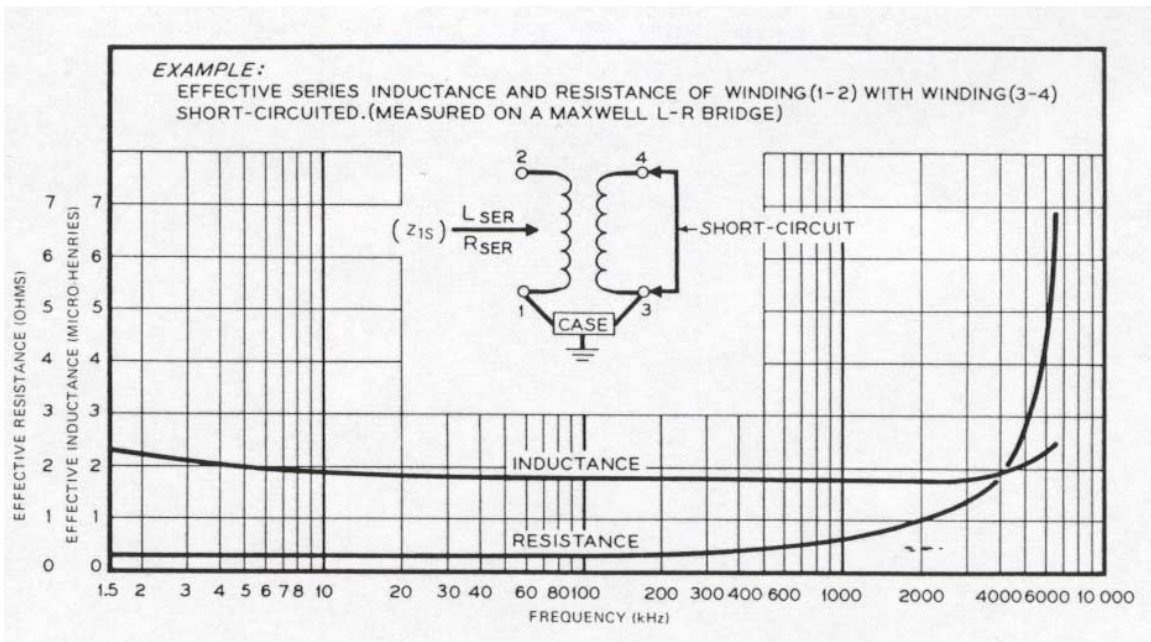

Figure 2—Example of an effective series inductance and resistance of winding (1-2) with winding (3-4) short-circuited

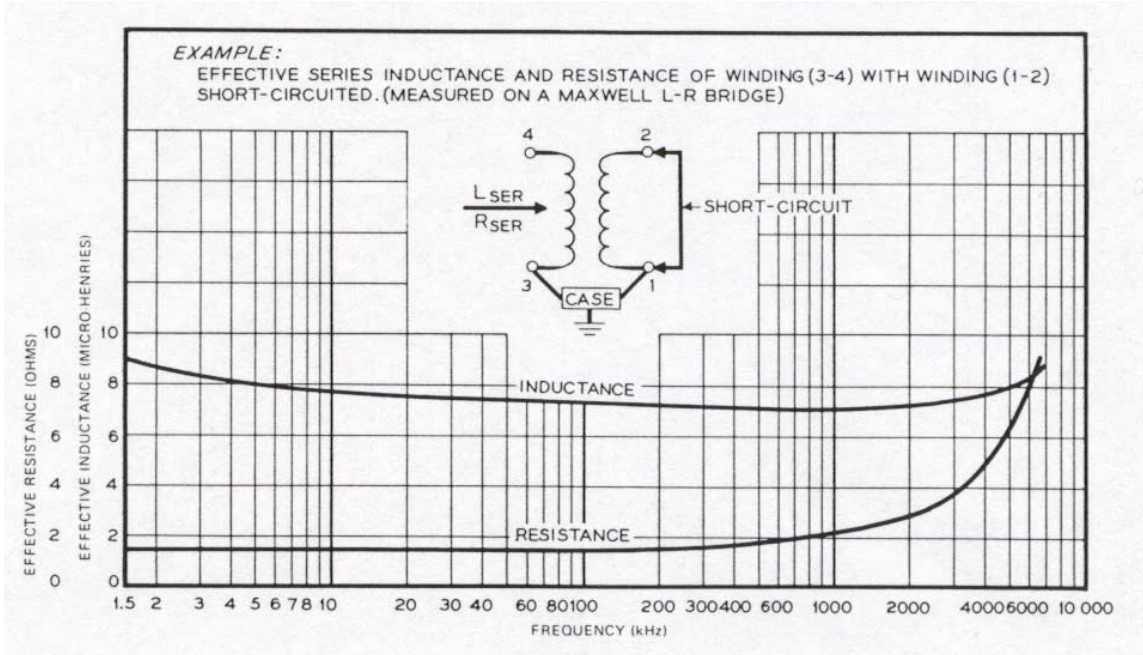

Figure 3—Example of an effective series inductance and resistance of winding (3-4) with winding (1-2) short-circuited

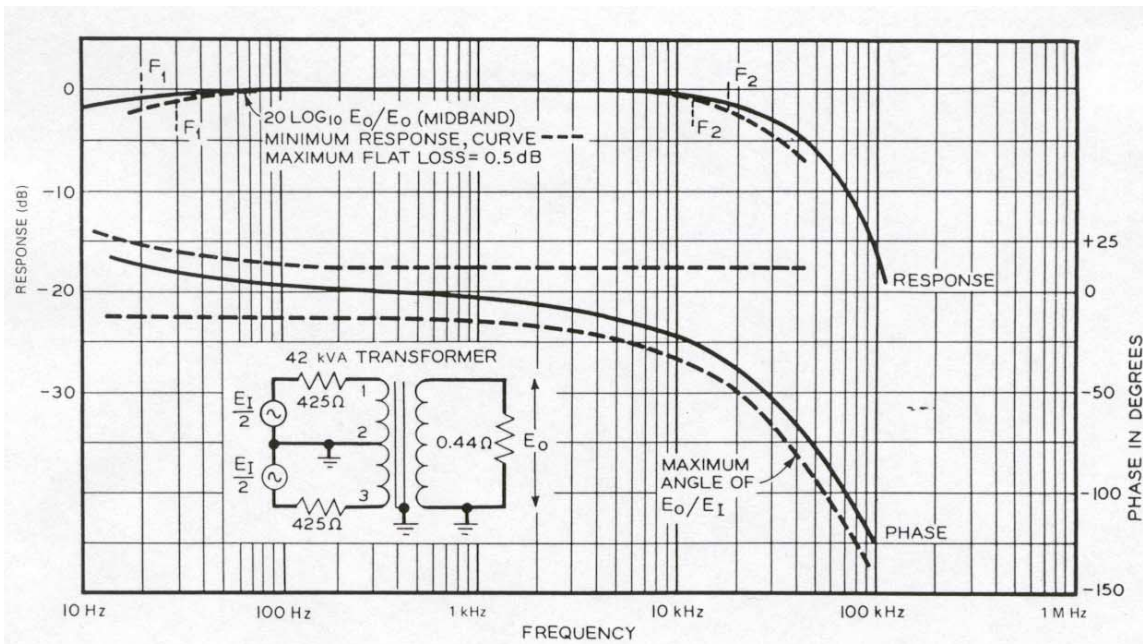

Figure 4—Example of the response of a transformer with matched resistive terminations and typical curves of maximum phase and minimum frequency response

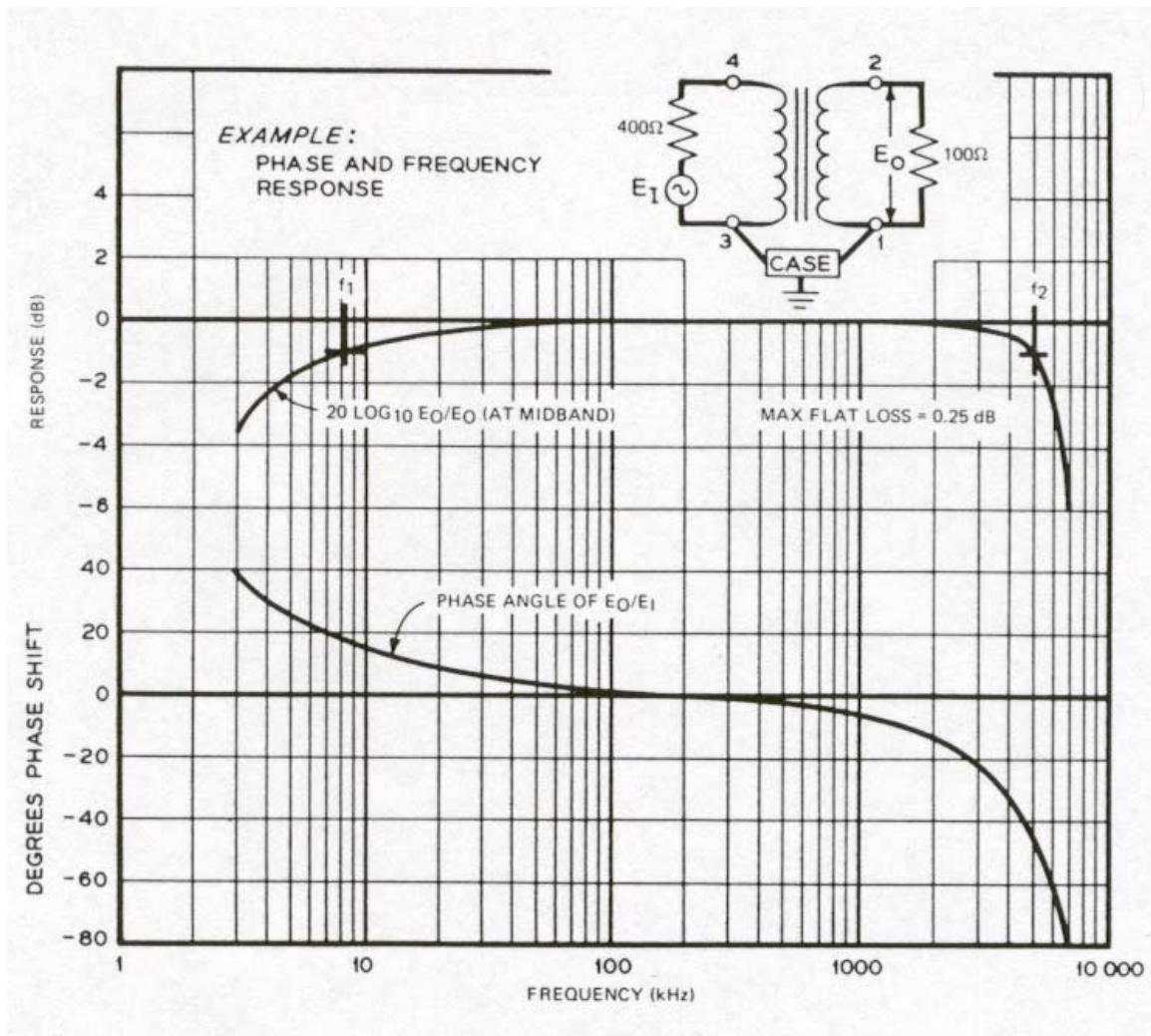
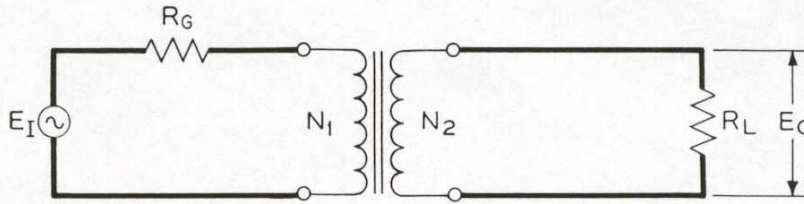

Figure 5—Example of phase and frequency response

Transformer equivalent circuit



(a) Amplitude frequency = $20 \log_{10} \frac{E_O}{E_I}$ at mid-band frequency response (see NOTE 1 and Fig 1)

(b) Transformer loss = $20 \log_{10} \frac{1}{2} \sqrt{\frac{R_L}{R_S}} - 20 \log_{10} \frac{E_O}{E_I}$ (matched source and load assumed)

(c) Voltage amplification or attenuation = $20 \log_{10} \frac{E_O}{E_I}$ (see NOTES 1 and 2 and Fig 2)

NOTES: (1) When (a) or (c) is used to present data, the maximum value of (b) at mid-band frequency, should also be given. This is usually designated as “maximum flat loss.”

(2) (c) may also be designated as “transfer function” if phase responses are also included.

Equivalent circuit

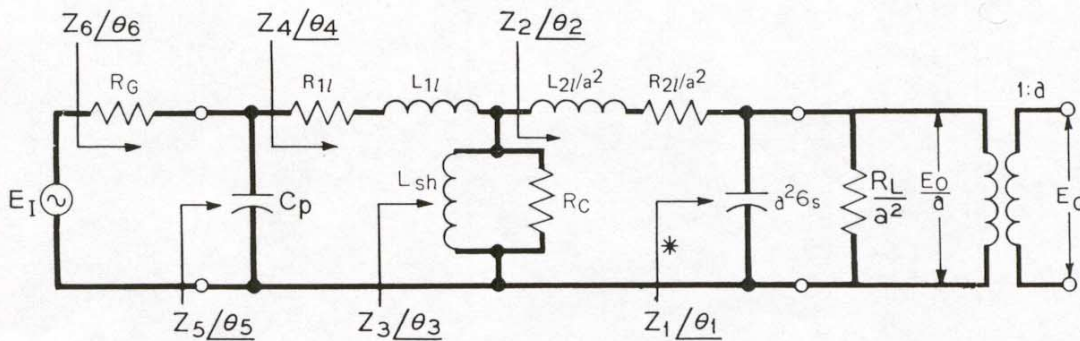

*To be read as: Z_1/θ_1 equals the impedance of the circuit to the right of the arrow with everything to the left of the arrow disconnected.

(1) $\frac{E_O}{aE_I} = \frac{Z_1/\theta_1}{Z_2/\theta_2} \cdot \frac{Z_3/\theta_3}{Z_4/\theta_4} \cdot \frac{Z_5/\theta_5}{Z_6/\theta_6} = (\text{ratio}) / \theta$

(2) Ideal transformer: $\frac{E}{aE_I} = \frac{1}{2} / \theta$ (at all frequencies)

(3) Nonideal transformer: $\frac{E_O}{aE_I} = (\text{ratio} < \frac{1}{2} / \theta)$

Figure 6—Response definitions

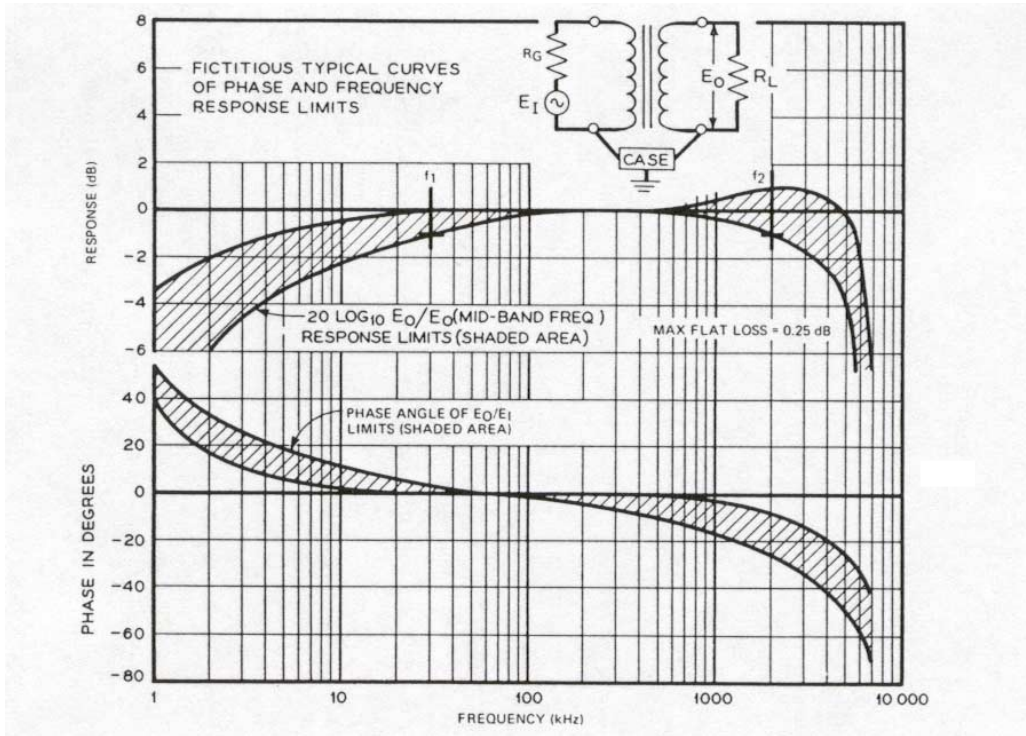

Figure 7—Fictitious typical curves of phase and frequency response limits

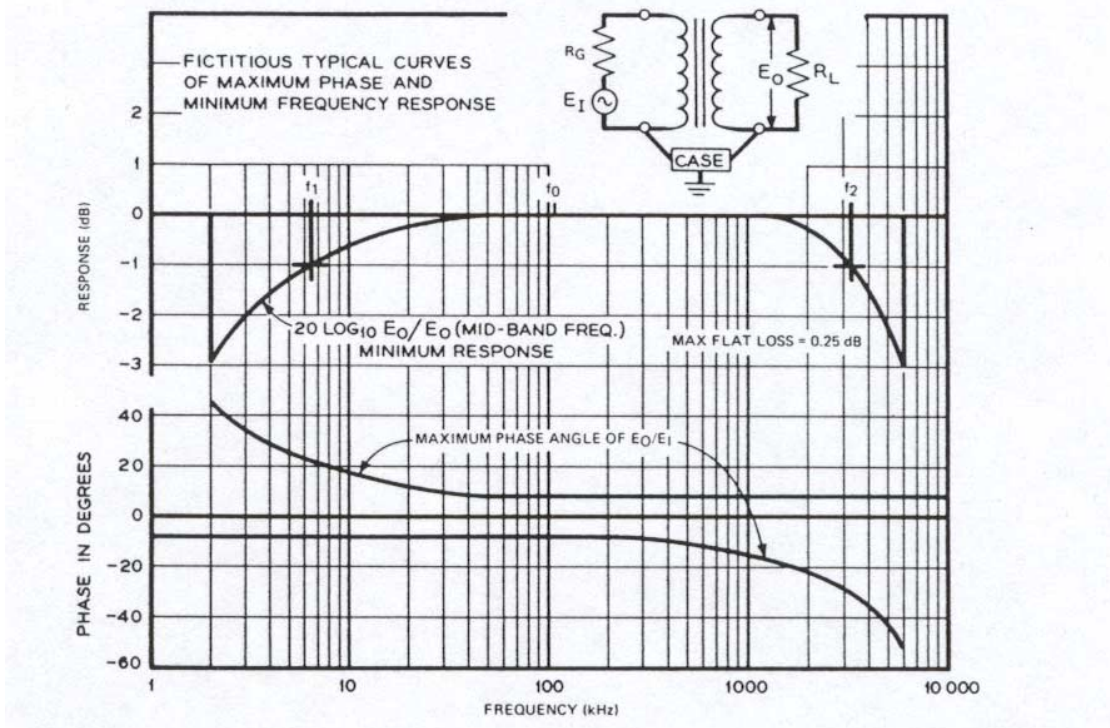

Figure 8—Fictitious typical curves of maximum phase and minimum frequency response

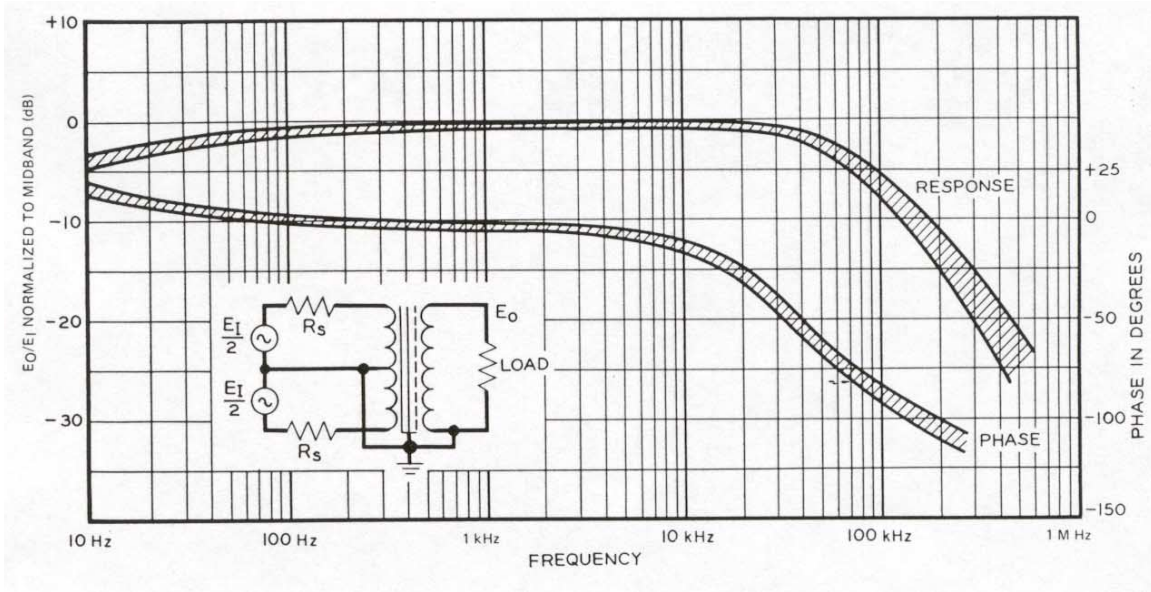

Figure 9—Example of the tolerance band of the response of a transformer with matched resistive termination

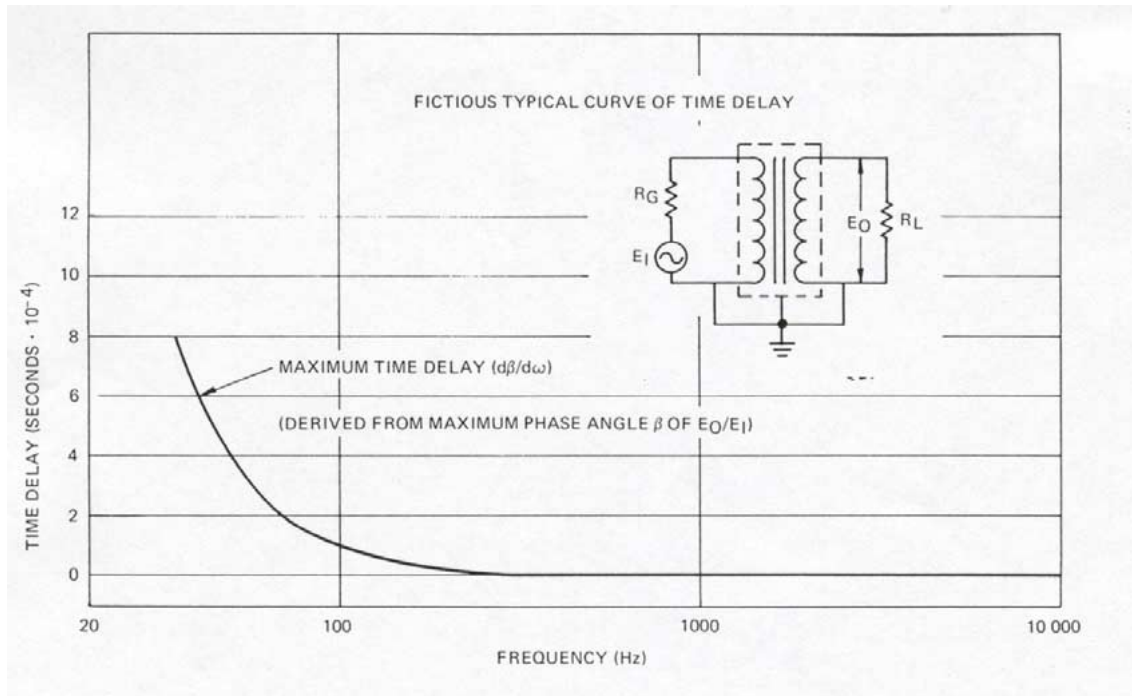

Figure 10—Fictitious typical curve of time delay

5.2.6 Terminated impedance measurements (when terminated as in 5.2.2.) (See 9.5 of this standard and Figure 11—Figure 13.)

Terminated impedance of the primary should be measured at minimum specified frequency, at mid-band frequency (see Clause 4), at maximum specified frequency, and also at one octave higher, or as specified, provided, however, if resonance occurs, that all maximum values should be measured in the interval. The actual load should be used if available; a simulated load may be used but this should be representative of the reactive and resistive element of the actual terminations plus any parasitic elements in the associated power supplies (in the case of modulation transformers). Unless otherwise specified, the mid-frequency and high frequency tests may be made at low voltages. The loaded impedance at low frequencies may also be plotted by this means, providing the shunt inductance of the system is relatively constant for various flux densities. Tests, according to 5.1.9, should be used to ascertain the low-frequency full-power performance compared to the low power-level test. Various low-frequency power sources which may be used with the transformer should be used in loaded or unloaded tests at full voltage to determine the shunting effect of the transformer and associated inductors on the load.

With Class B and AB amplifier output transformers having dual primaries (or a center tapped primary), the terminated impedance test should be made on each of the primaries separately. If the performance of one primary differs from the other, then both should be measured and reported. Unless otherwise specified, a direct current equal to 5% of normal direct current in the primaries should be used in making open-circuit inductance or impedance measurements. The full value of direct current (if any) in the secondary should be used.

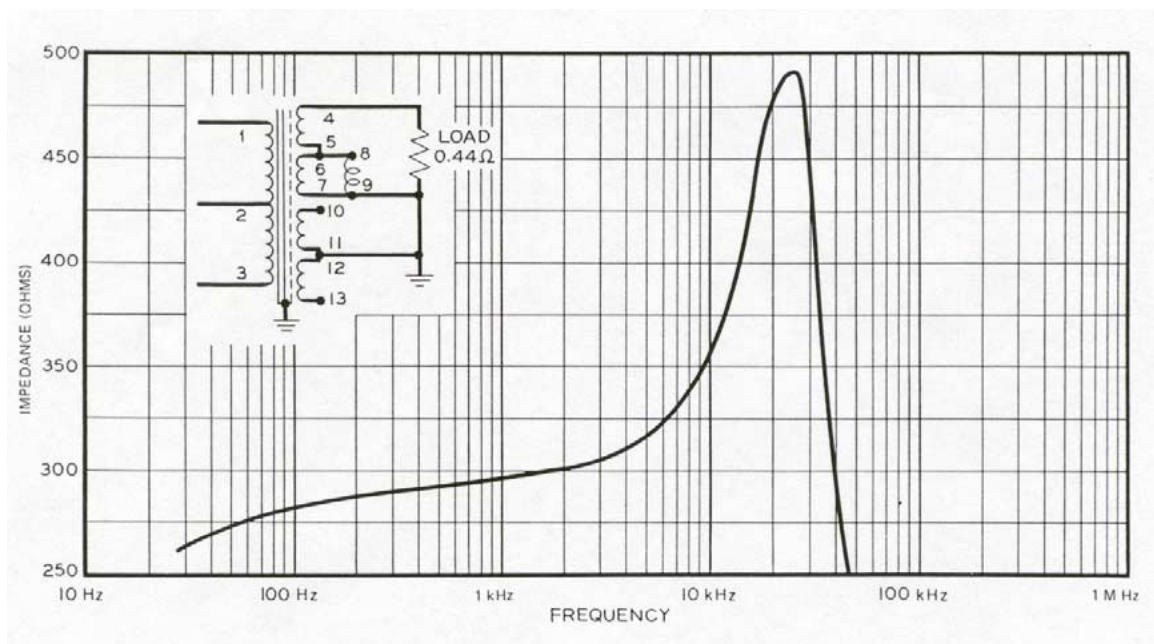

Figure 11—Example of the impedance of windings (1-3) with windings (4-7) terminated

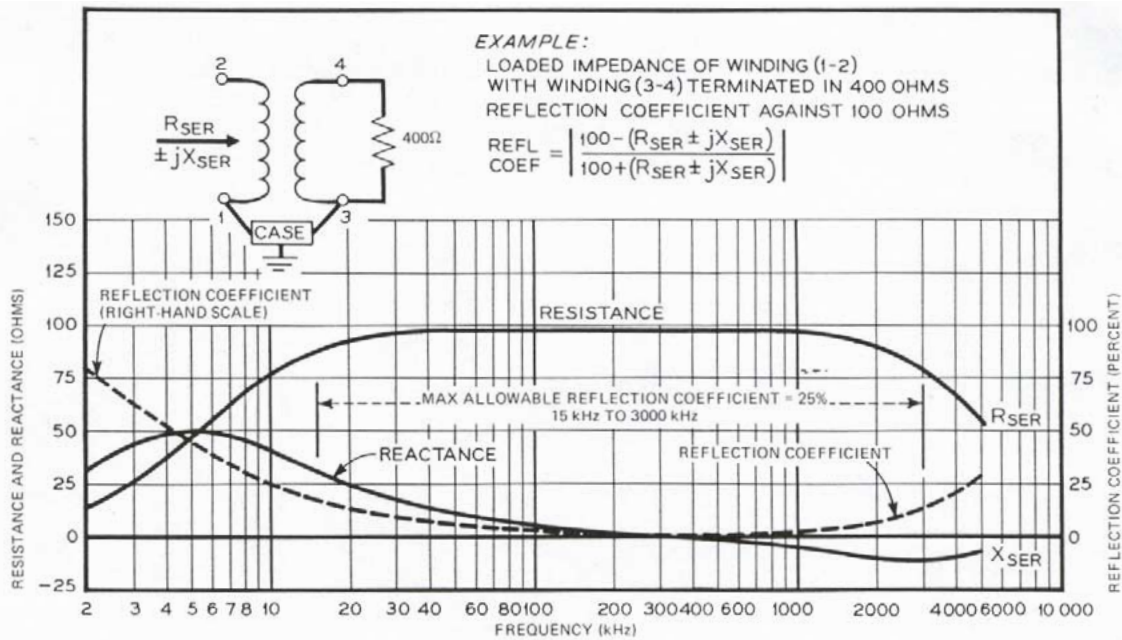

Figure 12—Example of return-loss resistance and reflection coefficient curves for a fictitious transformer

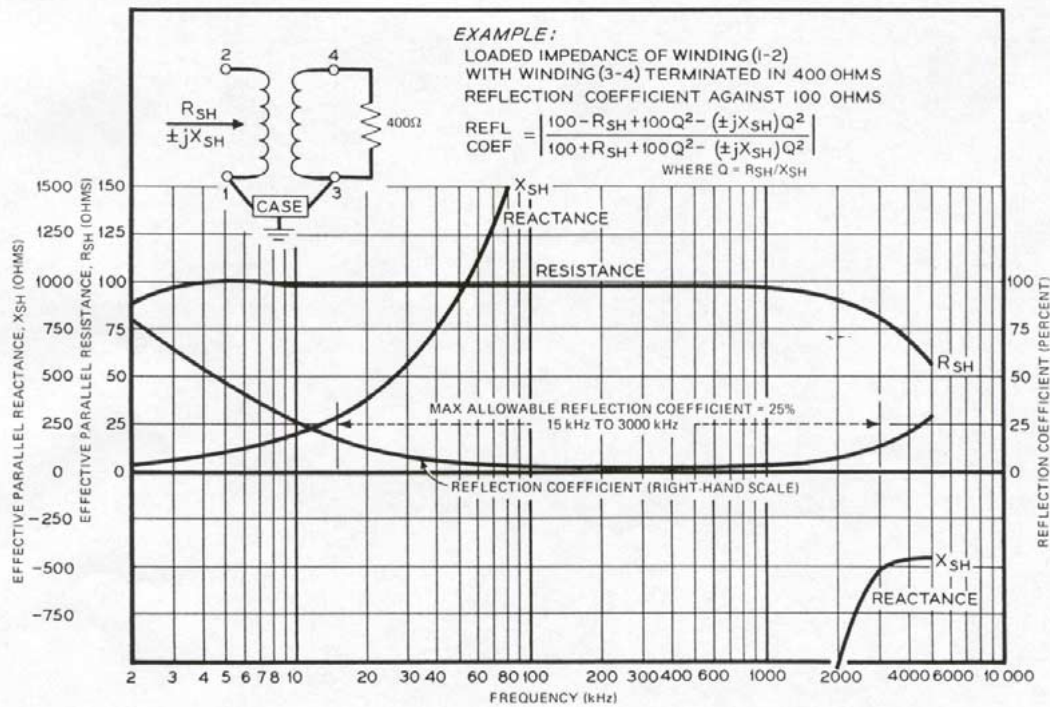

Figure 13—Example of loaded impedance and reflection coefficient curves for a fictitious transformer

5.2.7 Balance

If balance measurements are specified, they should be made in accordance with 9.2. Unless other frequencies are specified, the measurements should be made at frequencies near

- a) The low-frequency 1 dB point
- b) The mid-band frequency
- c) The high-frequency 1 dB point

5.2.8 Modulation measurements

These measurements may be specified if the information is important in the end use of the transformer.

NOTE: Transformers used in circuits operating at very low voltage levels may require inter-modulation products to be 40 dB to 80 dB below the level of the lowest frequency transmitted. Examples of such transformers are those used in bridge detectors and voice and carrier circuits.

5.2.9 Open-circuit impedance measurements

These measurements may be specified if the information is required for calculations (see 9.3). The open-circuit impedance, normally as a matter of convenience, is specified in terms of the effective shunt inductance L and shunt resistance R . If done in any other way, the form must be stated (see 9.4). Open circuit impedance is normally measured on the low-impedance winding near the lower 1 dB response frequency, f_1 , and at the rated voltage with rated direct-current superimposed on the windings. If it is impractical to make the measurements at this voltage, or if the transformer is required to work over a wide range of voltage levels, such as random-noise transformers, other test voltages may be used; however, when voltages other than the rated voltage are used the test voltage should be reported with the measurements. Measurements should be made, when applicable, with added direct current in the primary or secondary windings as noted in 5.2.4.

6. Marking

The markings that may be specified shall be done in a manner which is legible and permanent on an area which is plainly visible when the transformer is mounted by normal means. The following markings are illustrative of the sort that may be specified.

6.1 Nameplate markings

- a) Manufacturer's name or identification
- b) Manufacturer's number
- c) Source and load impedances
- d) Direct current in winding
- e) Maximum power output
- f) Frequency response limits
- g) RMS working voltage
- h) Turns ratio if other than R_S/R_L (see 5.1.3)

6.2 Terminal markings

- a) Windings should be numbered (1-2), (3-4), in preference to (1 - 3), (2- 4), etc.
- b) Windings numbered (1-2) and (3-4) should be series aiding when 2 is connected to 3.
- c) If a separate shield terminal is provided, it should be suitably marked (for example, "s").
- d) If deviations from the above terminal markings are used, the winding polarities and impedance levels shall be clearly stated.

7. Service conditions

Conditions for which the transformers covered by this standard are suitable depend the application. The following are illustrative of the sort of conditions that may be specified.

- a) Audible noise
- b) Humidity
- c) Temperature
- d) Altitude
- e) Vibration
- f) Shock
- g) Dimensions
- h) Flammability

Tests for these conditions, when specified, should be agreed upon between user and manufacturer.

8. Computations

Information is provided in 9.3 which may assist the system engineer if it is necessary to make computations of transformer response, phase shift, or loaded impedance.

9. Test methods

9.1 Temperature rise tests

- a) The transformer shall be tested in a circuit simulating normal operating conditions.
- b) The device for measuring the ambient temperature changes by means of an oil bath or other suitable material.
- c) The device for measuring the temperature of the core or case shall be secured in contact with the surface to be measured by means of metal-sash putty or other suitable materials.
- d) The transformer shall be protected from air drafts and radiation from warmer objects.
- e) The tests may be performed at room temperature.
- f) The test shall continue until the temperature of the core or case shows constancy for three successive readings at intervals of at least 30 min.
- g) The average measured temperature of the winding may be determined by either of the following equations:

$$t = \frac{R}{R_{\theta}} (t_1 + t_0) - t_1 \quad (3)$$

or

$$t = \frac{R - R_{\theta}}{R_{\theta}} (t_1 + t_0) + t_0 \quad (4)$$

where

- t = temperature in °C corresponding to hot resistance R
- t_0 = temperature in °C corresponding to cold resistance R_{θ}
- R_{θ} = cold resistance determined as outlined below

R = hot resistance determined as outlined below
 t_1 = 234.5 °C for copper
= 225 °C for aluminum

In applying these equations, the cold resistance, R_θ , shall be measured after conditioning the transformer for at least 8 hours in a location free from drafts and until three successive temperature readings of the ambient and core or case, taken at 30 min intervals, are constant; this constant temperature shall be t_0 . The observed hot resistance, R , shall be measured as soon as practicable after shutdown (allow sufficient time for induction effect of winding to disappear). Record the elapsed time between the instant of shutdown and the hot measurement. (The elapsed time should be within 15 s for transformer weighing less than 10 lb.)

- h) The temperature rise of the transformer shall be computed by subtracting the temperature of the ambient air around the transformer at the end of the test from the temperature of the winding or of the core (whichever is higher) at the end of the test.

9.2 Balance tests

The test circuits shown in Figure 14 shall be used where specified for determining the balance of the transformer windings. Matched resistors of the precision type shall be used for the resistor pairs R_1 , R_2 and R_3 , R_4 . The sums, $R_1 + R_2$ and $R_3 + R_4$, shall equal, within 1%, the terminating impedance specified for the associated windings. The test may be made at any frequency, but frequencies near the low-frequency 1 dB point, the mid-band frequency, and the high-frequency 1 dB point shall be used unless other frequencies are specified. In general, at the low frequencies, the elements contributing to unbalance will usually be winding resistance and turns; in the middle frequencies, winding turns; at the high frequencies, leakage inductances and winding capacitances. The test is not limited to two-winding transformers and the test circuit may be modified as required. For additional information on balance measurements refer to Munk, P. R., and Sartori, E. F. A. [B16].

9.3 Computations

9.3.1 General

The purpose of this section is to provide basic information needed to compute transformer response and phase shift from the equivalent circuit of a transformer. These computations will have to be made by the audio or control system engineer when one is unable to specify the source and load impedances with sufficient accuracy to make it worthwhile to measure the transformer with these loads at the manufacturers' plant. Amplitude and phase response with resistive terminations are readily supplied by the transformer manufacturer. (This information may be only a rough guide to the system engineer.) If the load or the source, or both are not constant over the specified frequency range, the engineer shall supply this information to the transformer manufacturer, to allow the determination of the overall response through calculations or tests. If the system engineer is unable to do this initially, the problem may be solved in two steps: 1) The known transformer parameters, such as open-circuit inductance, short-circuit inductance, and distributed capacitance, are furnished by the manufacturer to the system engineer, and 2) The system engineer studies the effect of these parameters on the circuit to determine whether a satisfactory overall response is obtained. If it is not, modifications of the transformer or circuit must be made accordingly.

Formulas are included in Figure 6, Figure 15, Figure 16, and Figure 17 which relate the elements of the transformer equivalent circuit to the open- and short-circuited impedances which may be measured on a transformer. Accurate equivalent circuits may be obtained at the frequencies of measurement. However, it is often sufficiently accurate to obtain equivalent circuits at the low, middle, and high frequencies of a band and assume that the element values will remain constant for these respective sections of the frequency band.

In order to illustrate the character of the open- and short-circuited impedances of a transformer, data was taken on actual transformers, plotted, and included in this section (see Figures 1, 2, 3, 4, 9, 11, 18, 19, and 20). Response and phase-shift data taken on these same transformers with resistive terminations are included also for reference (see Figure 2, Figure 3, and Figure 4).

In Figure 15, primary open-circuit and short-circuit impedances are measured. Likewise, secondary impedances are measured. The relationships between these measured impedances on a unity turns ratio basis are given by the equations in Figure 15. That is, the measured impedances are divided or multiplied by the square of the turns ratio to refer them to the same impedance level. Because no transformer is *ideal*, as *ideal* is defined in The Authoritative Dictionary of IEEE Standards Terms; the symbol “ a ” is only approximately equal to the turns ratio, N_2/N_1 .

It is possible to relate the several impedances and admittances to an equivalent circuit of the T , π , or L form by equations given in Figure 15. In the L network, the influence of coil geometry is directly manifest in the product at which effectively modifies the turns ratio. Calculations have been made of the circuit elements for T , π , and L network equivalents of the 1:2 ratio transformer chosen as an example, and the values are tabulated in Figure 17. In the L network, element values are fairly constant with increasing frequency, physical behavior is accurately portrayed, and analysis is simple. For these reasons, the L network is adopted as standard. If a transformer has a step-down turns ratio, its network should be viewed from the right in Figure 17.

In the case of hybrid transformers, the term *perfectly balanced* can best be illustrated by referring to Figure 25. For this symmetrical single-core hybrid transformer, perfect balance is attained when $Z_1=Z_2$, and there is infinite trans-hybrid loss from port 0 to port 3. (In practice, the trans-hybrid loss may be as low as 20 db to 30 db without appreciably affecting transmission characteristics.)

For transmission from port 0 to ports 1 and 2, Z_3 can be ignored completely and the equivalent circuit becomes that of a two winding transformer with the secondary termination consisting of Z_1 and Z_2 in series.

The two-core hybrid configuration may be analyzed as two winding transformers essentially in series, providing the conjugate port can be neglected.

For cases where either the non-conjugate impedances are not balanced across the frequency range of interest or the trans-hybrid loss is required, 9.3 is inadequate and computer-aided circuit analysis of the equivalent circuit is mandatory.

A. BALANCE DEFINITION

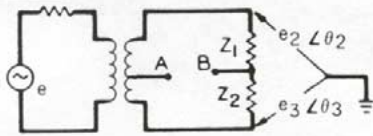

$$\text{TRANSFORMER BALANCE} = 20 \log_{10} \left| \frac{e_2 \angle \theta_2 - e_3 \angle \theta_3}{e_2 \angle \theta_2 + e_3 \angle \theta_3} \right| \text{ dB}$$

RESTRICTIONS:

A, B OR BOTH MUST BE GROUNDED

$$Z_1 = R_1 + jX_1 = Z_2 = R_2 + jX_2$$

B. BALANCE TEST METHODS

GROUND CONDITIONS		TEST METHOD	TEST CIRCUIT	BALANCE EQUATION	NOTES
TERMINAL A	TERMINAL B				
GROUNDED	GROUNDED	I	1a or 1b, 1c	$20 \log_{10} e_2/e_1 - 20 \log_{10} e_4/e_3 + 6.02 \text{ dB}$	1, 2, 3, 4, 6, 7
FLOATING	GROUNDED	II	2a or 2b, 2c	$20 \log_{10} e_2/e_1 - 20 \log_{10} e_4/e_3 + 6.02 \text{ dB}$	1, 3, 4, 6, 7
GROUNDED	FLOATING	III	3a or 3b	$20 \log_{10} (e_3 \angle \theta_3 - e_4 \angle \theta_4)/e_2 \text{ dB}$	1, 3, 5, 6, 7

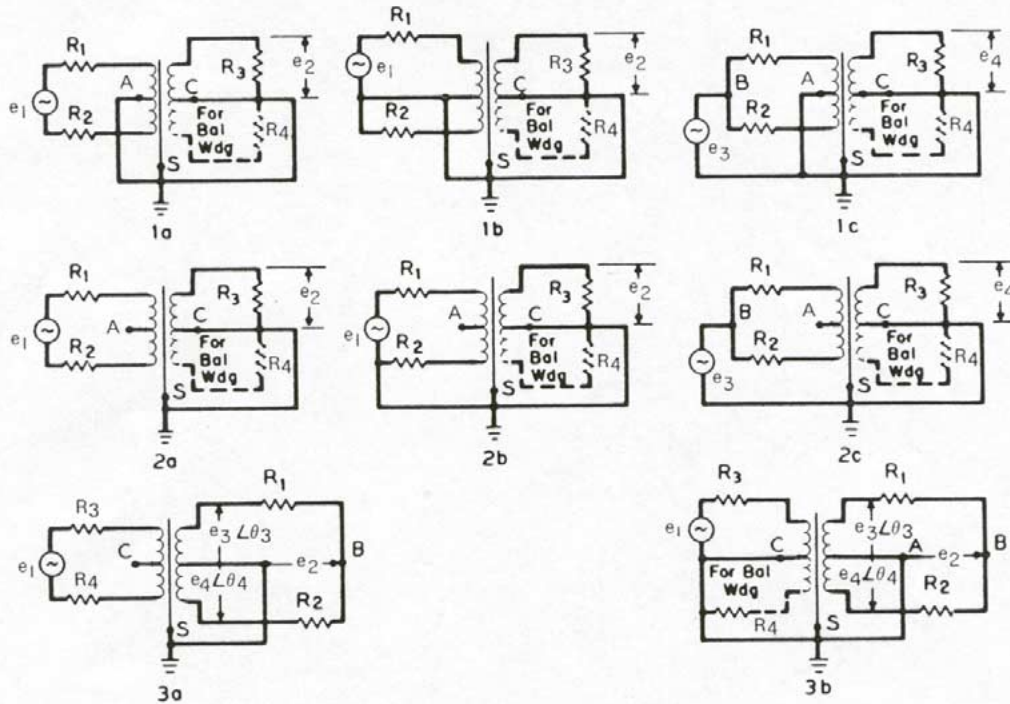

- NOTES: (1) Winding with terminations R_1 and R_2 is the winding under test.
 (2) Test method I is the same as that for longitudinal balance, transformer balance is 6.02 dB greater than longitudinal balance.
 (3) Where both windings are balanced, center tap C should be grounded or floating as required to simulate use condition.
 (4) When $e_1 = e_3$, balance = $20 \log_{10} 2e_2/e_4$.
 (5) Ideally, $e_3 = -e_4$; only a small approximation gives balance = $20 \log_{10} e_3/e_4$.
 (6) 1a, 2a, and 3a require a balanced source. If the transformer balance is 20 dB or better, an unbalanced generator may be used as in 1b, 2b, and 3b with less than 1 dB error.
 (7) In all cases, $R_1 = R_2$ and $R_3 = R_4$.

Figure 14—Balance definition and balance test methods

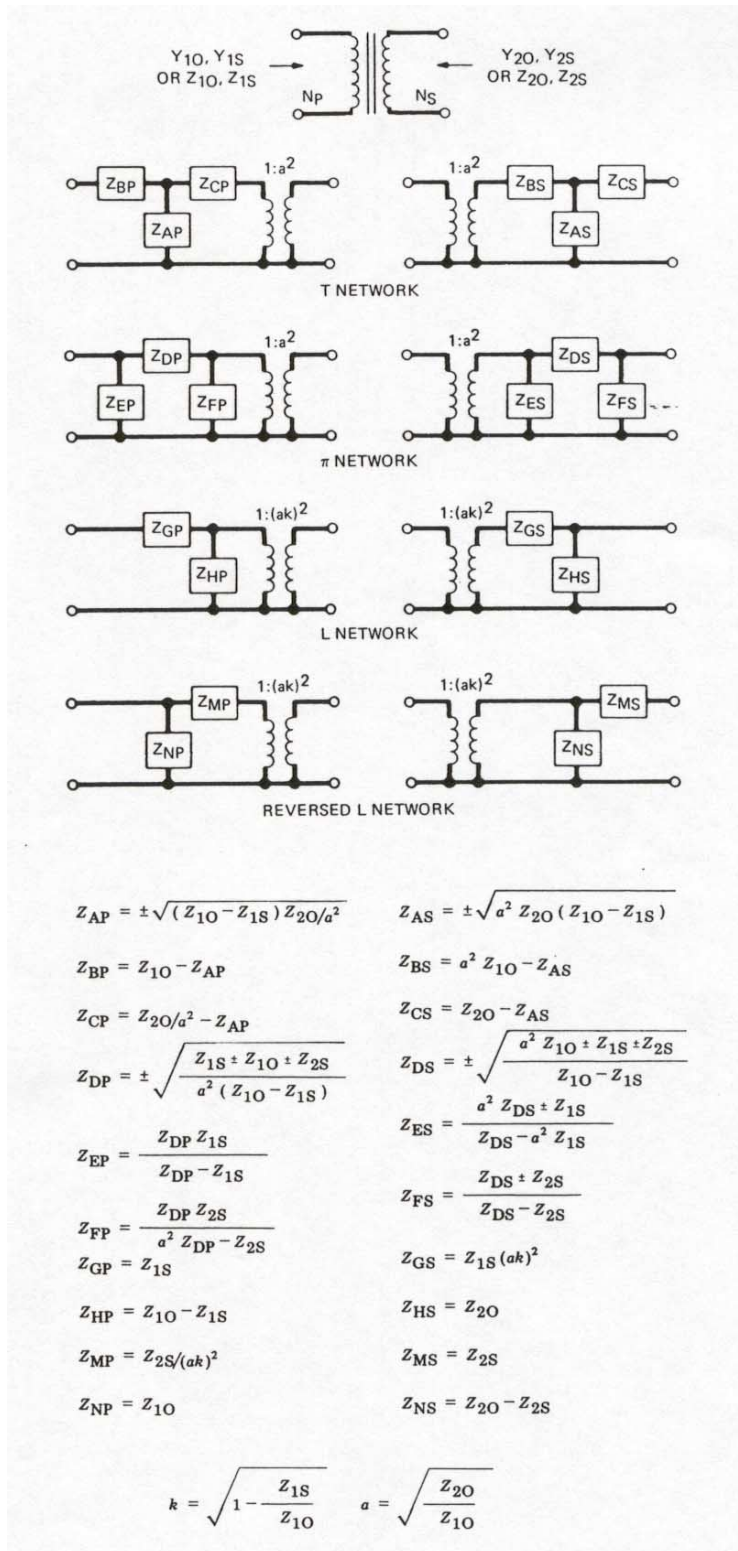

Figure 15—Three-terminal equivalent networks determined from open- and short-circuit measurements

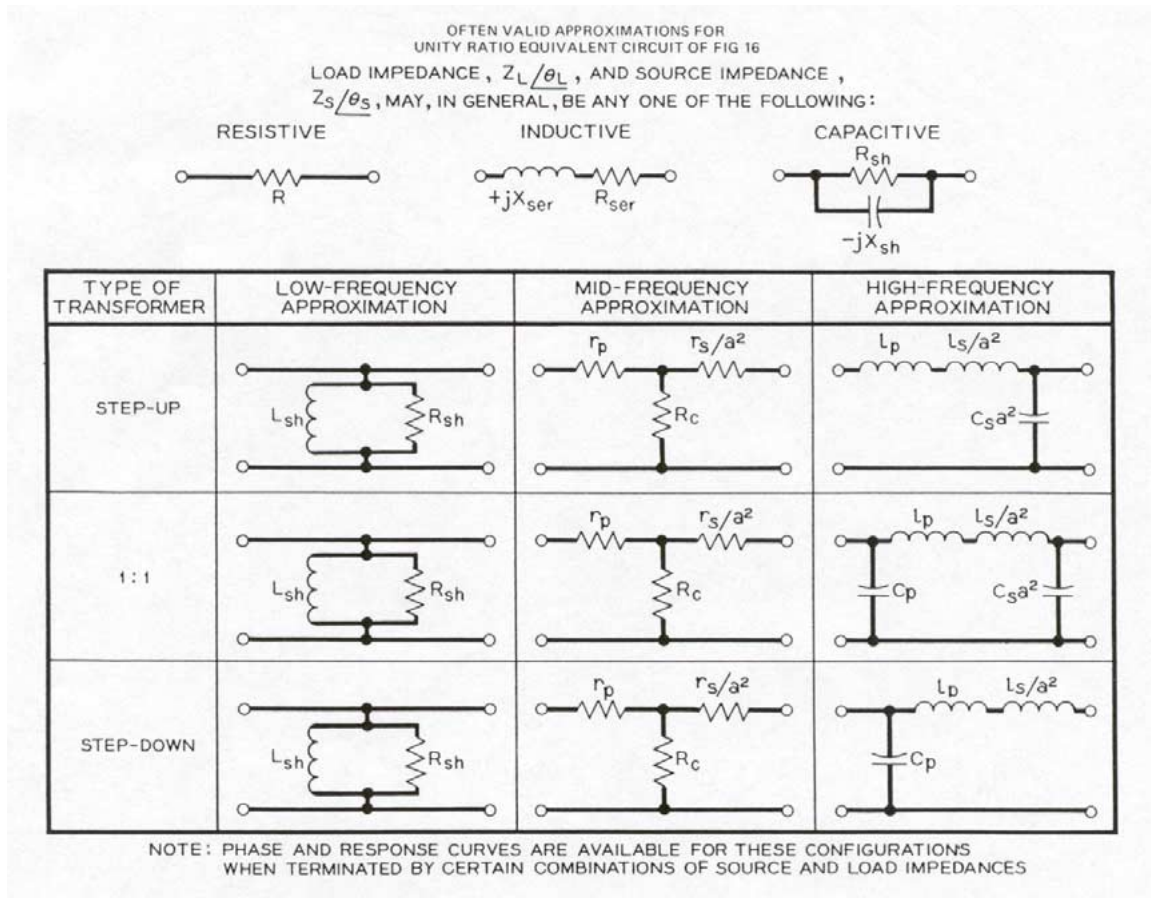

Figure 16—Often valid approximations for equivalent circuit of Figure 6

9.3.2 Procedure

Certain supplementary information will be provided by the transformer engineer to the system engineer to enable the latter to compute response and phase shift as a function of frequency for reactive source and load impedances. Accordingly, the following steps to be taken are recommended for the engineers involved:

- a) The transformer engineer shall establish nominal value equivalent circuits from measurements taken on the transformer (see Figures 1, 2, 3, 4, 9, 11, 18, 19, 20, and 21 for some of the measurements on sample transformers) for:
 - 1) Equivalent circuits for low-frequency end of band
 - 2) Equivalent circuits for mid-frequency portion of band
 - 3) Equivalent circuits for high-frequency end of band (see Figure 6, Figure 15, and Figure 16).
- b) The transformer engineer shall check the validity of these equivalent circuits by making computations (see Figure 15) using matched resistances for source and load impedances and comparing results with the measured response according to 5.2.2 and 5.2.3.
- c) The transformer engineer shall establish expected deviations of all elements of the equivalent circuits from the nominal values and supply this information with a), items 1), 2), and 3).

- d) The system engineer shall make mesh computations, using nominal values of elements for the mesh and for source and load impedance, by the method outlined in Figure 6. This will provide both transformer response and phase shift information over the frequency band of interest. In general, enough points should be computed to establish the 1 dB points and the slope beyond these points and any significant resonances.
- e) The system engineer shall make a deviation study, using expected deviations of element values furnished, to establish suitability of the manufactured product for the system source and load impedances.

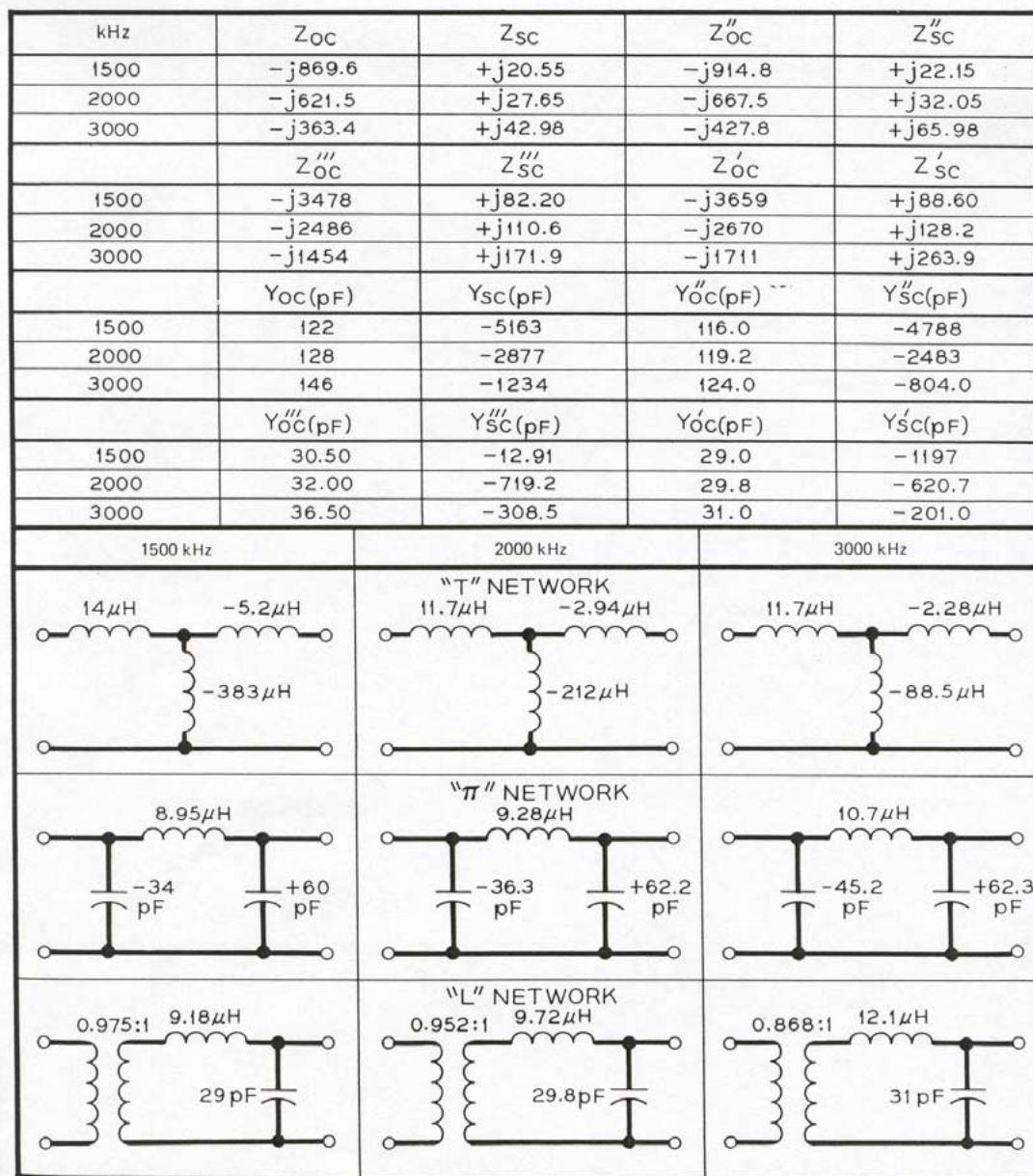

Figure 17—Impedance characteristics of transformers used in examples

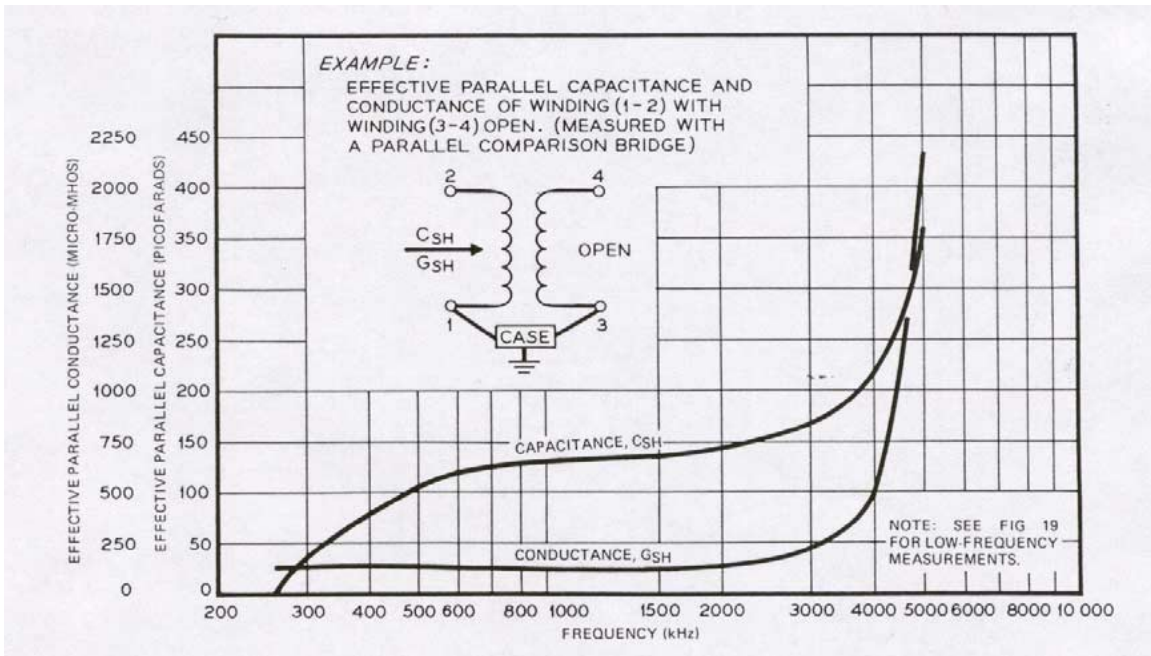

Figure 18—Example of an effective parallel capacitance and conductance of winding (1-2) with winding (3-4) open

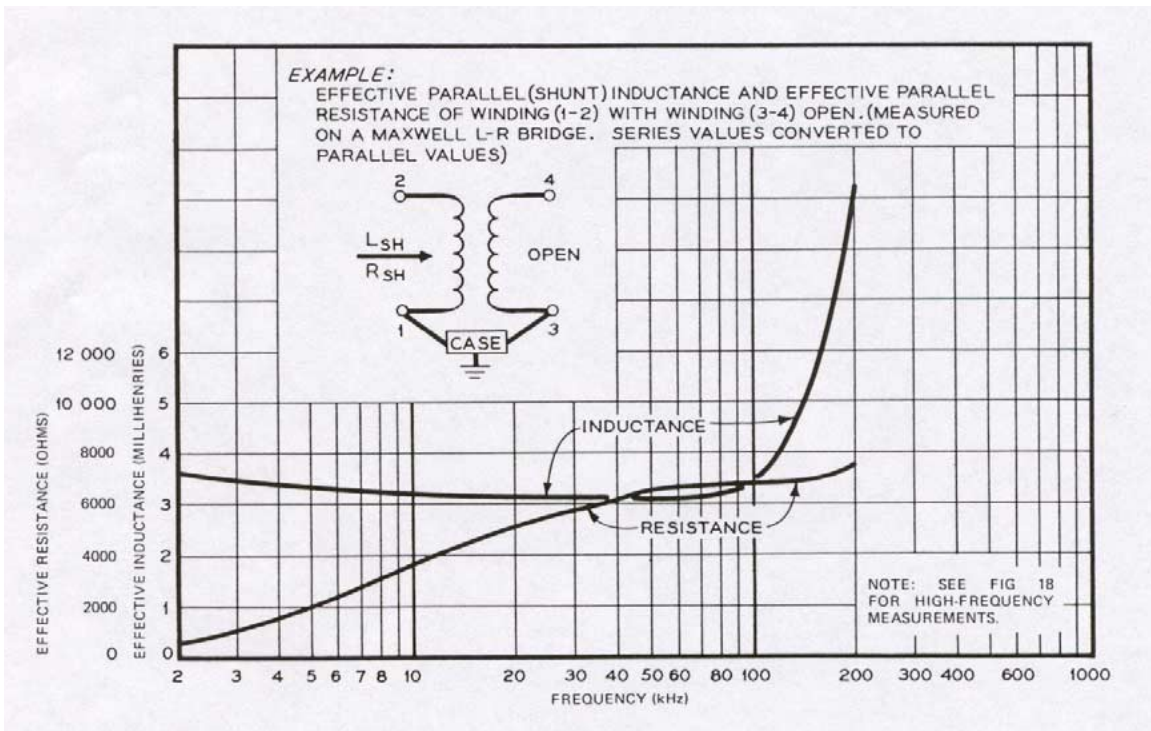

Figure 19—Example of effective parallel inductance and resistance of winding (1-2) with winding (3-4) open

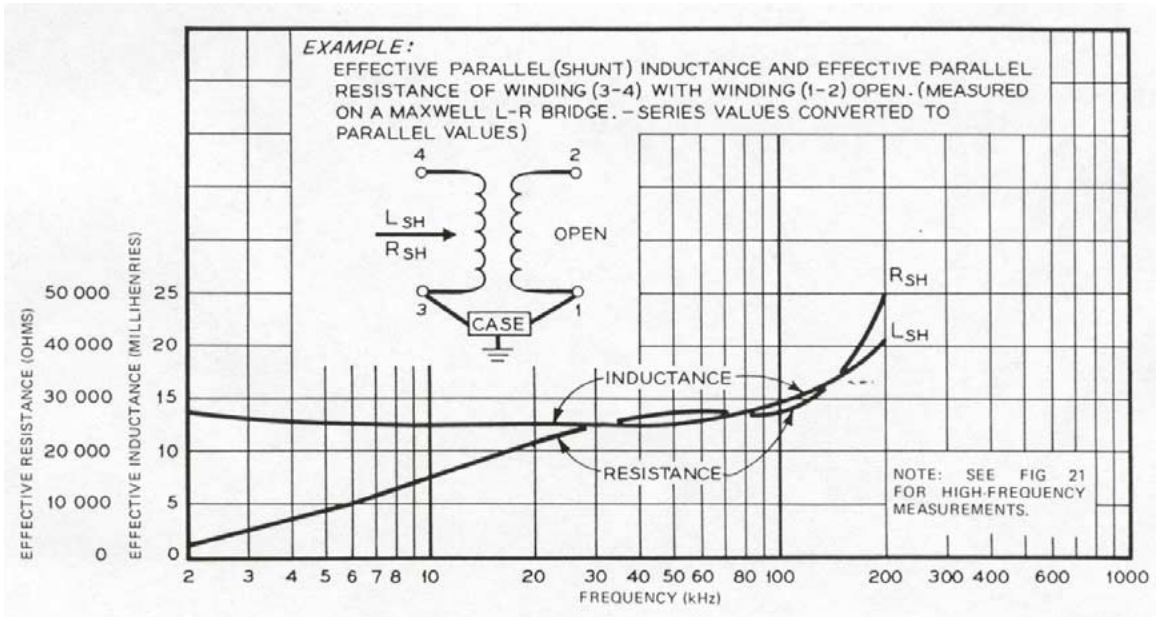

Figure 20—Example of an effective parallel inductance and resistance of winding (3-4) with winding (1-2) open

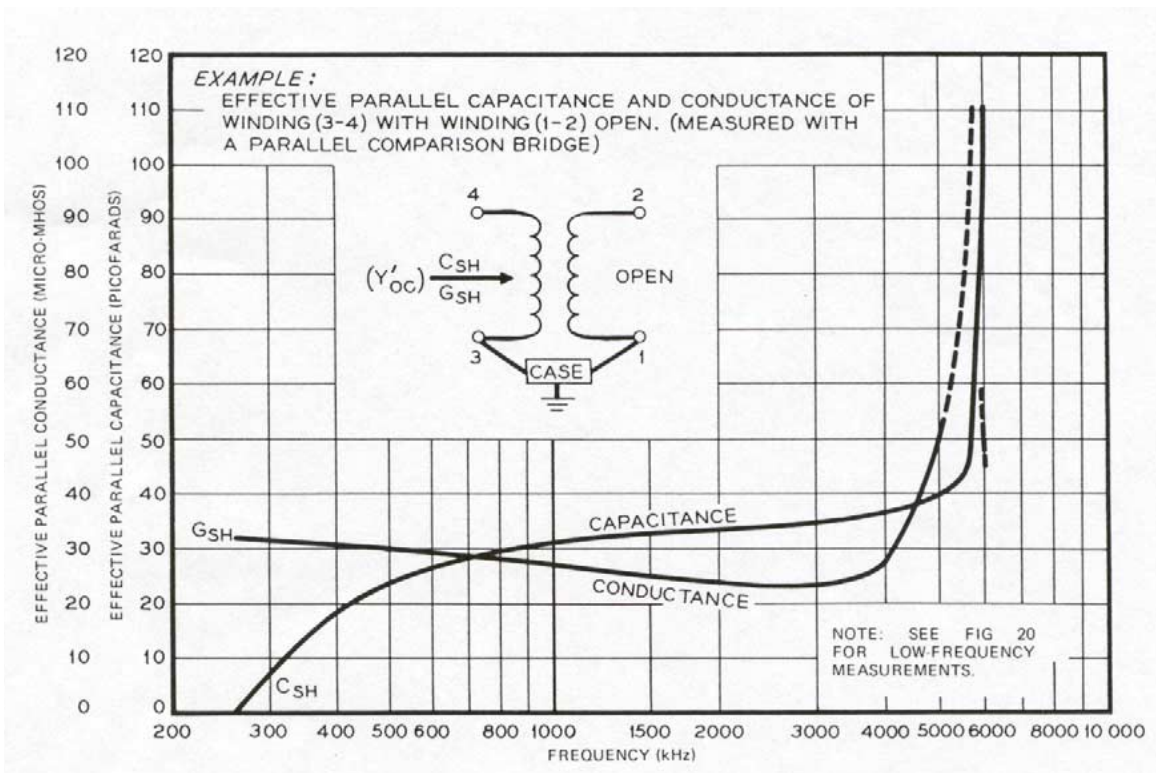

Figure 21—Example of an effective parallel capacitance and conductance of winding (3-4) with winding (1-2) open

9.4 Measurement of open-circuit and short-circuit inductance and resistance

Unless careful attention is paid to the measurement of open-circuit inductance, serious inaccuracies may result. It is the purpose of this subsection to point out possible ways in which open-circuit inductance and effective resistance may be represented and measured.

In a wide-band transformer, the core is usually composed of ferrite, or high-permeability material wound as a continuous strip or with a very small air gap. Under these conditions, the Q , or ratio of effective series reactance to effective series resistance, is small. Both inductance (L) and Q are dependent on the voltage level and frequency used and this is the reason for specifying the design value of voltage and lowest frequency in 5.2.6. Winding resistance ordinarily has a much smaller value than the core-loss equivalent series resistance in this kind of transformer. Short-circuit inductance is very small compared to mutual inductance. Therefore, it is more representative of actual performance to regard open-circuit inductance and core-loss resistance as parallel elements, L_{sh} and R_{sh} . Open-circuit reactance increases proportionately as frequency increases above the minimum, so that at mid-band frequency and higher frequencies open-circuit reactance becomes so large it is virtually negligible. Core-loss resistance does not change nearly so fast with frequency. Both inductance, L_{sh} , and equivalent parallel resistance, R_{sh} , are most significant at the lowest frequency; but at mid-band, the open-circuit reactance may ordinarily be neglected, whereas the parallel equivalent resistance may contribute appreciably to mid-band transformer loss. For the parallel representation:

$$Q = R_{sh} / (2\pi f L_{sh})$$

At any frequency, it is possible to convert from series to parallel equivalent by using the two expressions for Q ; this conversion is unnecessary if the proper bridge configuration is used.

The two methods of representing open-circuit inductance and associated resistance, and also three common ways of measuring this inductance and resistance, are shown in Figure 22, together with the balance equations for each. These circuits are tabulated for user convenience. It should be noted that if a method is used in which inductance has a Q -dependent term, the Q measurement must be very accurate to provide an acceptable basis of measurement, particularly at low values of Q .

Equation 5 through equation 8 may be useful if it is necessary to convert from the series representation to the parallel representation, or vice-versa.

$$R_{sh} = R_{ser}(1 + Q^2) \quad (5)$$

$$R_{ser} = \frac{R_{sh}}{1 + Q^2} \quad (6)$$

$$L_{sh} = L_{ser} \left(1 + \frac{1}{Q^2} \right) \quad (7)$$

$$L_{ser} = \frac{L_{sh}}{1 + (1/Q^2)} \quad (8)$$

In transformers designed to cover a wide frequency band, particularly in miniature units, the direct-current resistance of the windings can result in incorrect measured values of short-circuit inductance. To reduce this error, it is good practice to measure open-circuit inductance near the low-frequency, and short-circuit inductance near the high-frequency ends of the operating range.

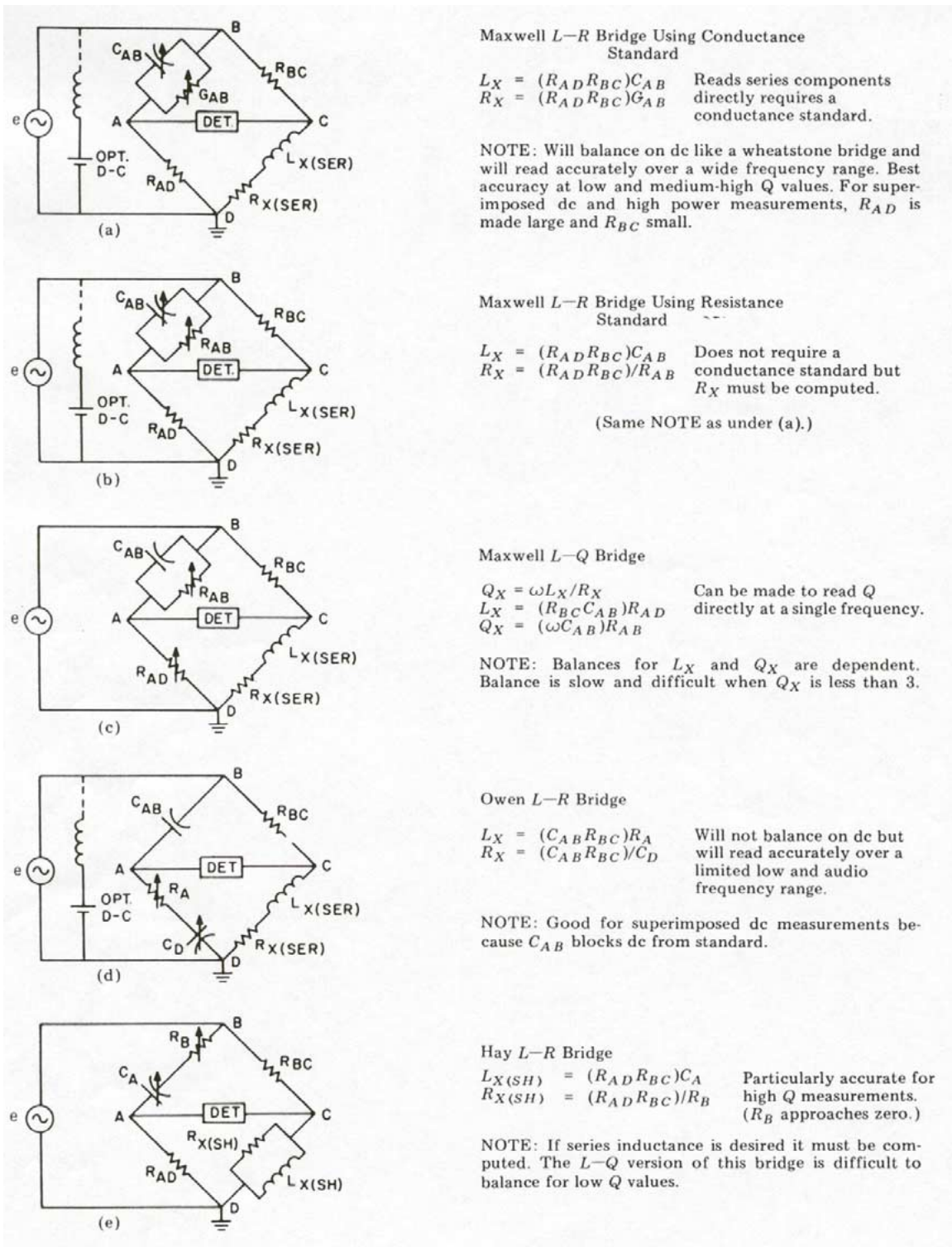

Figure 22—Impedance bridge

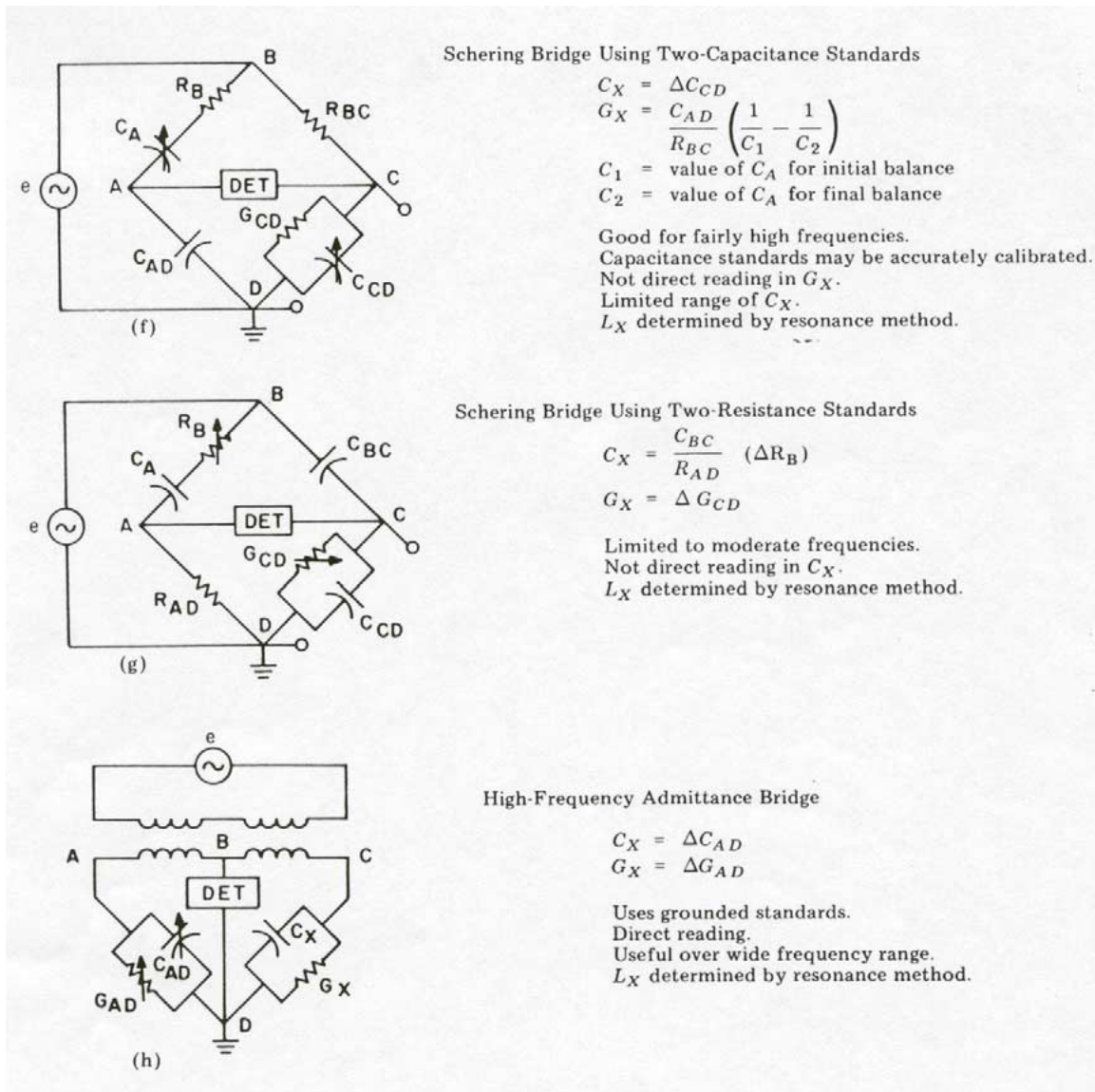

Figure 22—Impedance bridges (continued)

9.5 Terminated impedance measurement

Terminated impedance measurements may be required when it is necessary to limit reflections on a transmission line to a minimum value. The degree of mismatch is given in terms of the reflection coefficient between the impedance of the line and the impedance looking into the transformer when it is terminated in its nominal termination. The reflection coefficient may be determined from series impedance measurements (see Figure 12), from parallel measurements (see Figure 13), or by means of return loss measurements described in 9.5.1.

9.5.1 Return loss method

A rapid and convenient method of making return loss or reflection coefficient measurements requires an appropriate return-loss bridge. The bridge may take the form of the examples in Figure 23. To obtain highest accuracy, an impedance match should exist at each port except for the unknown port. The output voltage at the detector is directly related to the mismatch and, therefore, the reflection coefficient at this port.

The two-core hybrid bridge of Figure 23(b) is the most complex but permits matching of arbitrary impedances at input, detector, standard, and unknown ports. The single-core hybrid, Figure 23(c), permits matching of arbitrary impedances at input, standard, and unknown ports. Unless an additional transformer is used at the detector port, the detector impedance should be half the standard impedance. In the resistance bridge, Figure 23(d), and the reflectometer, Figure 23(e), the balance is derived from the resistors of the resistance bridge rather than the balance of the transformer. The transformers in the latter two cases are unbalanced to balanced devices to permit grounding both signal source and detector. In the case of the resistance bridge, the transformer permits arbitrary match at the input. The reflectometer requires equal impedances at all ports.

The method of test is similar for all of the devices of Figure 23. Referring to Figure 24, the test procedure requires four transmission voltage ratios to be measured at each test frequency.

Let

$$T_1 = 20 \log_{10} \frac{E_0}{E_1} \text{ dB for position 1} \quad (9)$$

$$T_2 = 20 \log_{10} \frac{E_0}{E_1} \text{ dB for position 2, etc} \quad (10)$$

For a resistive bridge or resistance reflectometer, the average, $T_0 = (T_1 + T_2)/2$ will be approximately 12 dB if the value R_s is the design value and will be greater as R_s deviates from the ideal value. For a hybrid transformer bridge, T will be about 6 dB ideally, and will also increase as R is changed from the design value. T in position 3 is a check measurement to test the balance of the bridge. The difference $(T_3 - T_0)$ is a measure of the precision of the bridge. This difference should be 20 dB greater than the requirement of return loss imposed on the transformer. T_4 is obtained when the transformer under test is connected to the unknown terminal of the bridge. The return loss is given by Equation (11).

$$\text{Return Loss} = (T_4 - T_0) \text{ dB} \quad (11)$$

for the case where $R1$, $R2$, and RS are the values for which the bridge was designed.

It is possible to obtain satisfactory accuracy in certain cases merely by measuring the output voltage E_0 which will be designated e_1 , e_2 , e_3 , and e_4 for the four conditions. The voltage e_0 corresponds to T_0 in the case above and is determined by the formula

$$e_0 = e_1 \cdot e_2 \quad (12)$$

Condition e_3 provides a test of the bridge and should always be no greater than $e_4/2$.

The return loss in dB is given by equation 13.

$$\text{Return Loss} = 20 \log_{10} \frac{E_0}{E_1} \quad (13)$$

Note that errors will always be in the direction to show optimistic values of return loss. The error will be in the order of $[(T_2 - T_1)/2]$ due to mismatch and will vary from approximately 1 dB, if the balance of the bridge is 20 dB better than that measured from the transformer, to 6 dB if the bridge balance is equal to the balance of the transformer.

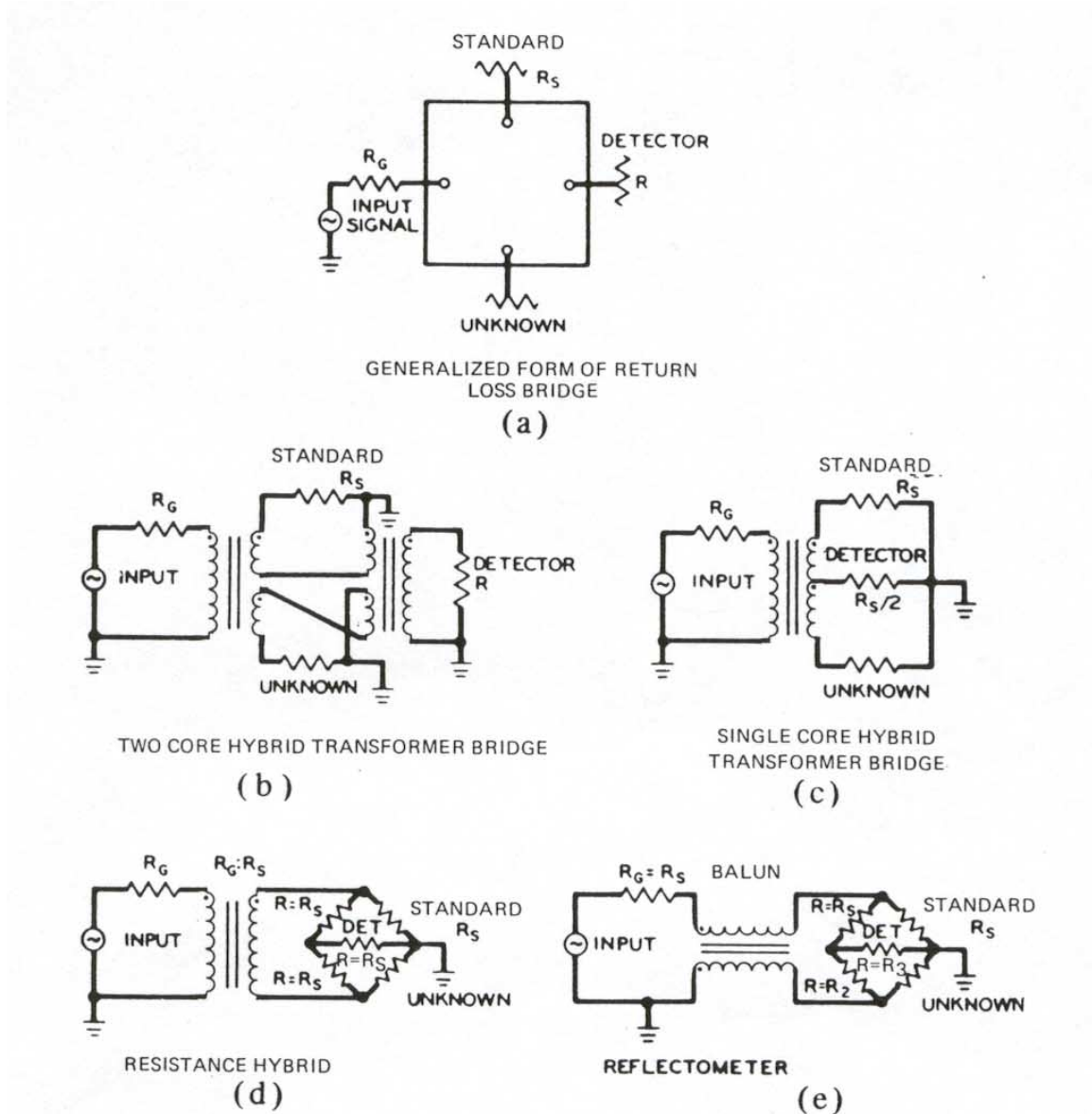

Figure 23—Return loss bridge

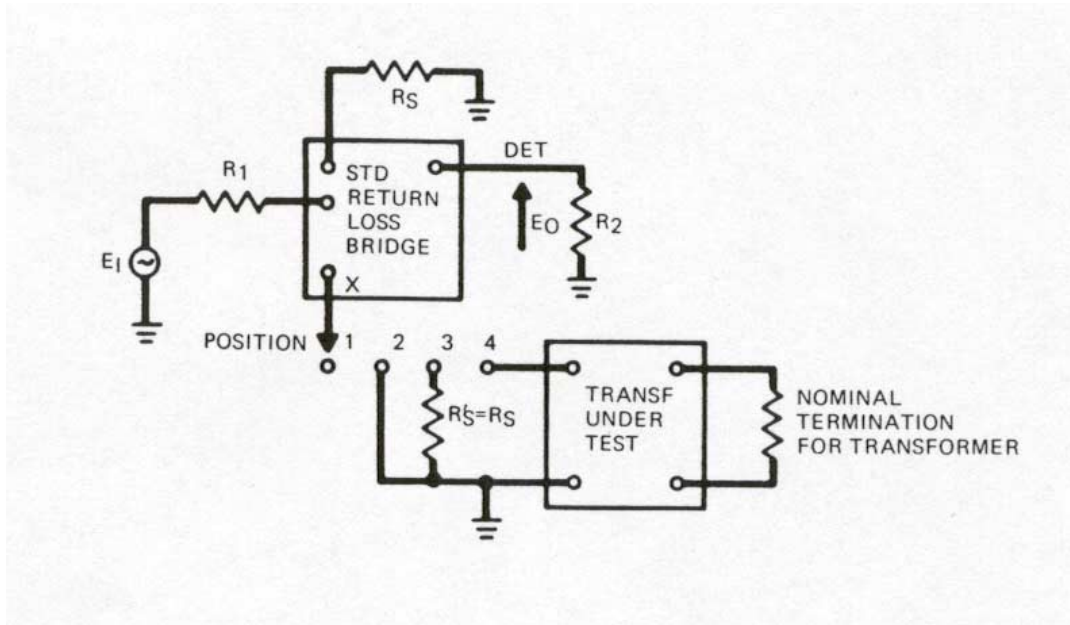

Figure 24—Return loss measurement

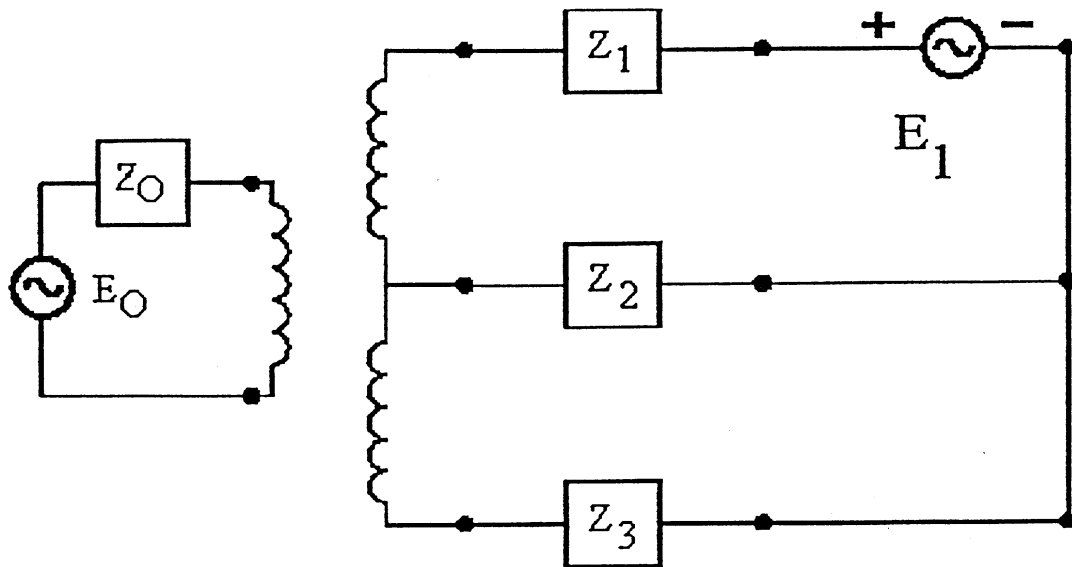

Figure 25—Hybrid transformer

Annex A

(informative)

Definitions and discussion

A.1 Primary winding

The primary winding is the winding(s) to which the input is applied. Where a center tapped or balanced primary is used, as in class A operation where both halves of the winding are substantially in simultaneous use, the whole winding shall be considered the primary.

Where Class B or Class AB mode of operation is used or where dual primaries operate on alternate half cycles, the primary winding should be considered as either winding separately, whether they be split or connected windings.

A.2 Peak working voltage (PWV)

NOTE—Because of the many types of voltages that occur in any electronic system, it is considered desirable to be specific in all references to voltage in order to convey the intended communications reliability. Working voltages actually apply to specific major insulations of the transformer, but for practical reasons must be identified by relating them to the various winding terminals.

- a) The peak working voltage (PWV) is the algebraic sum of the maximum normally recurring alternating crest voltages and direct voltage appearing between adjacent portions of two windings or grounded elements, or terminals thereof. The working voltage must be computed with the knowledge of the additive or subtractive relationship of the opposed alternating voltages across the specific major insulations.
- b) Where the induced peak voltage of a winding is no greater than 25% of the PWV for either end terminal, both terminals should carry the PWV rating of the greater.
- c) Where the induced peak voltage of a winding exceeds 25% of the PWV of either end terminal, the designer may elect to use a graded insulation system where a different kind or amount of major insulation is used at either end of the winding, in which case the insulation testing shall be in conformity with said conditions.

A.3 Insulation

A.3.1 Major insulation

Insulation external to the windings, and from windings to ground.

A.3.2 Graded insulation

The selective arrangement of the insulating components of a composite insulation system to more nearly equalize the voltage stresses through the insulation system.

A.3.3 Internal insulation

Insulation within the winding, between turns, coils, and layers.

A.4 Peak voltage

Peak voltage is the highest crest of simple or complex voltage wave or series of waves compared to zero voltage.

A.5 Transient voltage

Transient voltage is that part of the voltage response that eventually decays to zero in an exponential manner when the transformer is excited with a steady-state driving force. (For example, the high peak voltage often encountered when a power supply is switched on or when an electron tube cathode-to-plate flashover occurs.)

A.6 Maximum operating voltage

Maximum operating voltage is the normal maximum voltage, either rms or peak as stated, appearing across a winding. This is distinguished from surges, transients, etc.

Annex B

(informative)

Recommended practice for making electrical tests

Certain precautions and recommendations are covered in this annex as they may apply to the electrical tests outlined in Clause 5 of this standard.

- a) If corona tests are to be made, it is recommended that the units under test are at ambient temperature and free of any condensate (dry). As outlined in 5.1.6, corona tests are made in various ways depending on the relative voltages of windings compared to their voltages to ground and also depending on their type of insulation (see Annex A, and item b) and item c) of A.2). Corona tests should be made in accordance with IEEE Std 436-1977.
- b) Impulse tests are design tests and are not intended for 100% inspection tests; however, checkup tests may be indicated during production or acceptance tests. It is recommended that transformers and inductors requiring spark gaps or other arcing types of protection be subjected to impulse tests. Refer to Clause 3 of IEEE Std C57.98-1993 for information on impulse tests.
- c) No-load loss tests may be invalid unless the voltage sine-wave purity is maintained. Tests may be performed at other voltages and frequencies, provided that an equivalent demonstration of core performance is apparent.
- d) A number of precautions and the importance of some measurements and characteristics should be particularly emphasized for modulation although these may apply to other transformers as well. These are:
 - 1) Measurement of open-circuit impedances or loaded impedances should be made with appropriate direct current or representative unbalanced direct current.
 - 2) Particular care should be taken in the measurement of equivalent circuit elements. Inductance measurements by bridges are straightforward but may be subject to error unless care is taken in balancing the bridge properly. Other methods, such as resonance determination, can also be erroneous unless care is taken.
 - 3) A smooth response is important for proper operation of many transformers so the transmission characteristic and loaded impedance characteristics should be examined for freedom from peaks. Care should be taken to measure enough points in the frequency spectrum to ensure determination of all possible peaks in the complete transmission spectrum.
 - 4) Primary to primary balance in Class B or AB transformers is particularly important for good performance.
 - 5) The need for freedom from cyclic transients at high operating frequencies in Class B or AB transformers should be considered and specified as required.

Annex C

(informative)

Service conditions

This annex illustrates the sort of service conditions that can be specified and are often relevant to the transformers covered by this standard.

- a) *Visual and mechanical.* All units furnished should meet the dimensional and finish requirements of the applicable specifications and should be of such construction as to meet the environmental conditions indicated in the specifications.
The units shall be capable of withstanding, without damage, the normal handling incidental to shipping and installing in the equipment. Terminals and bushings should be of sufficient strength in proportion to the size and weight of the unit.
- b) *Special environmental tests.* Special environmental tests, including humidity, temperature extremes, altitude, vibration, shock, flammability, tilt, drop, impulse, sand erosion, submersion, salt spray, radiation, and sonic stress should be included in the specifications in a manner plainly evident to the manufacturer and user. Tests for these conditions should be agreed upon between user and manufacturer.
- c) *Acoustical noise level.* Where the acoustical noise level is important, it shall be suitable for the environment. The user shall specify the acoustical noise levels, the ambient acoustical noise, and the weighting factors of the measuring instrument.
- d) *Ambient temperature.* The ambient temperature range for air-cooled transformers is normally between $-20\text{ }^{\circ}\text{C}$ and $+50\text{ }^{\circ}\text{C}$, with the additional provision that air convection currents on five sides or 70% of the case surface should not be restricted. (Further, the radiation from a nearby hot surface is not present unless specified.) (The reflection coefficient of an opposite nearby surface is not present unless specified.)
- e) *Liquid-cooled units.* Water-cooled units shall presume an unlimited supply of liquid below 30 lb/in. The water shall be free from impurities that would be injurious to the materials used in the heat exchanger of the transformer.
- f) *Forced-air cooling.* Forced-air cooling should be covered in the specifications as to directions, temperature, and cubic feet per minute.
- g) *Physical location.* Electronic components are usually placed in a protective cabinet where the terminals are not accessible to accidental contact. Any other requirement or condition should be specified.
- h) *Clean and dry environment.* A clean and dry environment is considered normal.
- i) *Altitude.* Normal maximum altitude, unless otherwise specified, is 10 000 ft.
- j) *Duty cycle for voice and music transmission systems.* For normal applications, the long-term average of the subject signals based on continuous duty is assumed to be equivalent to a simple sine-wave of 30% of the maximum rms signal for 100% modulation, or 21% of the peak voltage. The rms level should be specified for random noise conditions.
- k) *Extraneous voltages.* Voltages other than those which the transformer was designed to transmit should not be allowed to enter the transformer windings. The allowable level of extraneous voltages depends on many factors but a maximum of 5% of rated voltage is suggested as a limit. An example of an extraneous voltage case is that of radio frequency voltages impressed on a modulation transformer due to inadequate filtering between the radio-frequency circuit and the audio-frequency modulation transformer.

Annex D

(informative)

Methods of computing time delay from phase shift measurements

Phase response measurements, in accordance with 5.2.3, provide the information to allow computations to be made of time delay in accordance with 5.2.4. If the maximum time delay is required, then the maximum tolerance of phase response, as shown in Figure 7, Figure 8, and Figure 9, is used. The slope of the tangent at the frequency of interest on this phase response versus frequency curve will provide the information for computing time delay to an accuracy that depends on how accurately the tangent was constructed. For example, if the tangent at 30 Hz intercepts the phase ordinate at 1.84° at 0 frequency and intercepts the frequency abscissa at 53 Hz at 0° , the time delay would be computed as follows:

$$\begin{aligned} \text{Time delay} &= \frac{1.84^\circ \cdot 0.01745 / \text{rad}}{53 \cdot 2 - \pi} & (\text{D.1}) \\ &= (96.4 - 10^{-6} \text{S}) \end{aligned}$$

A more accurate method requires plotting the phase response maximum tolerance curve on log-log paper. A straight line is then drawn which best fits all points in the region of interest. The equation of the line is:

$$\log_{10} \Phi = -m(\log_{10} f) + \log_{10} b \quad (\text{D.2})$$

Evaluate m and b and compute time delay as follows.

$$m = \frac{\log_{10} \Phi_1 - \log_{10} \Phi_2}{\log_{10} f_2 - \log_{10} f_1} \quad (\text{D.3})$$

$$b = \Phi_n \cdot f_n^m \quad (\text{D.4})$$

$$\frac{d\Phi}{df} = -m \cdot b \cdot f^{-(1+m)} \quad (\text{D.5})$$

$$\text{Time delay} = \frac{1}{360} \cdot \frac{d\Phi}{df} \text{ s} \quad (\text{D.6})$$

Let

$$f_2 = 100 \text{ Hz}$$

$$f_1 = 10 \text{ Hz}$$

$$\Phi_1 = 2.7^\circ$$

$$\Phi_2 = 0.29^\circ$$

then

$$\log_{10} f_2 - \log_{10} f_1 = 1.0$$

$$\log_{10} \Phi_1 - \log_{10} \Phi_2 = 0.969$$

$$\text{Slope } m = \frac{\text{difference of } \Phi}{\text{difference of } f} \quad (\text{D.7})$$

$$= \frac{0.969}{1.0}$$

$$= 0.969$$

$$\text{Equation of the line} = \log_{10} \Phi \quad (\text{D.8})$$

$$= -m(\log_{10} f) + \log_{10} b$$

Clearing the logs from equation D.8, we have

$$\Phi = \frac{b}{f^m} \quad (\text{D.9})$$

$$b = \Phi \cdot f^m$$

$$= \Phi \cdot f_1^m$$

$$= 2.7^\circ \cdot 10_{0.969}$$

$$= 25.14$$

as a check

$$b = \Phi_2 \cdot f_2^m$$

$$= 0.29^\circ \cdot 100^{0.969}$$

$$= 25.14$$

Substituting for b

$$\Phi = \frac{b}{f^m}$$

$$= b \cdot f^{-m}$$

$$= 25.14 \cdot f^{-0.969}$$

Differentiating the above equation for Φ with respect to f we have:

$$\frac{d\Phi}{df} = m \cdot b \cdot f^{-(1+m)}$$

$$= 25.14 \cdot (-0.969 \cdot f^{-1.969})$$

$$\text{Time delay} = \frac{1}{360} \cdot \frac{d\Phi}{df}$$

$$= \frac{1}{360} \cdot \frac{24.36}{f^{1.969}} \text{ s}$$

$$\text{at 30 Hz: } \frac{1}{360} \cdot \frac{24.36}{30^{1.969}}$$

$$83.54 \cdot 10^{-6} \text{ s (negative slope)}$$

Other frequencies that were found to be on the line may be computed from this data

$$\text{at 10 Hz: } \frac{1}{360} \cdot \frac{24.36}{10^{1.969}} = 726 \cdot 10^{-6} \text{ s}$$

$$\text{at 20 Hz: } \frac{1}{360} \cdot \frac{24.36}{20^{1.969}} = 185 \cdot 10^{-6} \text{ s}$$

NOTE—This example shows how time delay may be computed from phase-gain information. Test instruments that measure time delay directly are available.

Annex E

(informative)

Bibliography

[B1] ANSI/ASTM A346-74, Tests for Alternating Current Magnetic Performance of Laminated Core Specimens Using the Modified Hay Bridge Method.

[B2] Edmonds, R. H., and Kahn, E. H., Design Against Voltage Breakdown of Air, *Electrical Equipment Engineering*, October 1959.

[B3] EIA (formerly RETMA) Std RS-174, December 1956 (R1975), Audio Transformers for Electronic Equipment.

[B4] Heinrich, O. X., Corona Measuring Techniques and Their Use in Insulation Systems Evaluation, *IEEE Transactions on Component Parts*, vol CP-11, no 2, pp 299-316, June 1964.

[B5] IEEE 100, The Authoritative Dictionary of IEEE Standards Terms, Seventh Edition.

[B6] IEEE Std 260-1978, IEEE Standard Letter Symbols for Units of Measurement (SI Units, Customary Inch-Pound Units, and Certain Other Units).

[B7] IEEE Std 266-1969 (R1981), IEEE Test Procedure for Evaluation of Insulation Systems for Electronics Power Transformers.

[B8] IEEE Std 280-1968, IEEE Letter Symbols for Quantities Used in Electrical Science and Electrical Engineering.

[B9] IEEE Std 295-1969 (R1981), IEEE Standard for Electronics Power Transformers.

[B10] IEEE Std 390-1975, IEEE Standard for Low-Power Pulse Transformers.

[B11] IEEE Std 391-1976, IEEE Standard for High-Power (Greater than 300 Watts, Peak) Pulse Transformers.

[B12] IEEE Std 393-1977, IEEE Standard Test Procedures for Magnetic Cores.

[B13] IEEE Std 436-1977, IEEE Guide for Making Corona (Partial Discharge) Measurements on Electronics Transformers.

[B14] Lee, R., *Electronic Transformers and Circuits*, 2nd ed. New York: Wiley, 1955.

[B15] Lord, H. W., The Design of Broad Band Transformers for Linear Electronic Circuits. *Transactions of the AIEE (Pt 11)*, vol 69, pp 1005-1010, 1950.

[B16] Munk, P. R., and Sartori, E. F. A., Theoretical and Experimental Study of Transformer Balance, *IEEE Transactions on Parts, Materials, and Packaging*, vol PMP-4, no 1, pp 12-21, March, 1968.

[B17] Pidhayny, D. D., The Effect of System Transients on the Specification of Transformers (Wide-Band Transformer Systems), Aerospace Corp Rep, Second Printing, December 1963.

[B18] Pidhayny, D. D., The Specification of Control System Transformers Using a Dynamic Response Criterion, Raino-Woolridge Corp Rep M50-902, Jan 1959 (presented as an AIEE Conference Paper).

[B19] Sartori, E. F., Hybrid Transformers, *IEEE Transactions on Parts, Materials, and Packaging*, vol PMP-4, no 3, pp 59-66, September 1968.

[B20] Terman, F. E., *Electronic Radio and Engineering*, 4th ed. New York: McGraw-Hill, 1955.

[B21] Vore, M. P., Design of Random Noise Transformers. *Transactions of the AIEE (Pt I, Communication and Electronics)*, vol 78, pp 59-63, March 1959.

[B22] Wahlgren, W. W., Corona in Electronics Transformers, *Proceedings of the IEEE and EIA Electronics Components Conference*, p 120, May 1967.

[B23] Zimmerman, S., Consideration of Insulation Behavior in Wide-Band Electronic Transformers, AIEE Rep CP61-474.